

Sussex County Board of Supervisors Regular Meeting
Thursday, February 23, 2023 – 6 pm
General District Courtroom – Sussex Judicial Center
15098 Courthouse Road, Sussex VA 23884

ZOOM LINK

<https://us02web.zoom.us/j/87119841051>

Meeting ID: 871 1984 1051

=====

1. Commencement

- 1.01 Call to Order/Determine Quorum
- 1.02 The Invocation
- 1.03 The Pledge of Allegiance
- 1.04 Agenda Amendment(s)
- 1.05 Approval of Regular Agenda

2. Approval of Consent Agenda

- 2.01 Approval of Minutes: January 19 regular and January 26, 2023 Finance Committee Board of Supervisors Meetings
- 2.02 Warrants and Vouchers
- 2.03 Treasurer’s Report & Financial Update – *for information only*
- 2.04 Departmental Reports – *for information only*
- 2.05 Waste Management Tax Refund (Finance Committee Recommendation)
- 2.06 Sheriff’s Vehicle Replacement Budget Amendment
- 2.07 Courthouse Fire Department Extrication Equipment Purchase (Finance Committee Recommendation)
- 2.08 March 2, 2023 BOS Budget Work Session for Big Ticket Items – *for information only*
- 2.09 February 27, 2023 Public Meetings for Sussex County Fire & EMS Study– *for information only*
- 2.10 Public Safety Coordinator Position Reclassification and VRS Change
- 2.11 Berkley Group Emergency Management Support Services Budget Amendment
- 2.12 CHA Landfill Inspection Task Order Budget Amendment
- 2.13 Sussex Towns Economic Development Planning Grant Budget Amendment
- 2.14 Courthouse Renovation Project Budget Amendment

3. Recognitions/Awards/Presentation

- 3.01 FY22 Audit of Sussex County – Aaron Hawkins (Robinson, Farmer, Cox Associates)
- 3.02 Sussex County Solar Facility Application Review and Approval Process Overview – Lindsey Edwards (Berkley Group)
- 3.03 Anticipated Blackwater Solar Facility Application – Molly Dowless, Resident
- 3.04 Sussex Service Authority Fiscal Evaluation – Roland Kooch (Davenport) and Stevie Steele (CHA)
- 3.05 Sussex County Chamber of Commerce Update – Jesse Hellyer (President)

4. Public Hearing – none

5. Appointments

5.01 Appointment to District 19 Community Services Board

6. Action Items

- 6.01 VEDP Business Ready Grant Overview & Related Budget Amendments – David Conmy
- 6.02 Fire Engine Acquisition (Stony Creek and Wakefield VFDs) – Financing Resolution
- 6.03 Recommended Sussex County EMS Operations Plan – Thomas Hicks (Berkley Group)
- 6.04 Donation of Waverly Fire Department Engine 120 – Supervisor Fly

7. Citizens' Comments

8. Unfinished Business – none

9. New Business

- 9.01 Presentation concerning Solar Facilities – No Solar Group

10. Board Members Comments

- 10.01 Blackwater District
- 10.02 Courthouse District
- 10.03 Henry District
- 10.04 Stony Creek District
- 10.05 Wakefield District
- 10.06 Waverly District

11. Closed Session

- 11.01 Convene to Closed Session
 - a. Acquisition of real property for public purposes, pursuant to applicable Code Section 2.2-2711(A)3
 - b. Personnel Matters discussion involving consideration, or interviews of prospective candidates for employment; assignment, appointment, promotion, performance, demotion, salaries, disciplining, or resignation of specific public officers, appointees, or employees of any public body, pursuant to applicable Code Section 2.2-3711(A)1
 - c. Consultation with legal counsel, or briefing by staff or consultants about actual or probable future litigation, pursuant to applicable Code Section 2.2-3711(A)7
- 11.02 Reconvene to Open Session
- 11.03 Certification
- 11.04 Board Action, if any

12. Recess/Adjournment

- 12.01 Recess/Adjournment
- 12.02 Next Meeting, Thursday, March 16, 2023 at 6 p.m.

February 23, 2023

WARRANTS & VOUCHERS SUMMARY

TOTAL ALL WARRANTS FOR APPROVAL **\$715,474.59**

TOTAL ALL VOID CHECKS FOR APPROVAL **\$0.00**

ACCOUNTS PAYABLE WARRANTS:	CHECK NO.	AMOUNTS	PROCESS DATE
FOR MONTH OF January 2023	224007-224039	\$ 141,079.67	RUN DATE 1/05/2023
	224055-224127	\$ 103,879.75	RUN DATE 1/12/2023
	224129-224182	\$ 254,313.14	RUN DATE 1/19/2023
	224183-224232	\$ 2,310.00	RUN DATE 1/24/2023
	224245-224284	\$ 85,533.55	RUN DATE 1/26/2023
Total Regular Warrants		\$587,116.11	
PAY. DEDUCTION WARRANTS:	224040-224054	\$ 53,523.62	RUN DATE 1/13/2023
	224128	\$ 3,048.49	RUN DATE 1/17/2023
	224233-224244	\$ 51,384.77	RUN DATE 1/31/2023
Total Deduction Warrants:		\$107,956.88	
TOTAL VOUCHERS & WARRANTS FOR APPROVAL		\$715,474.59	
ACH PAYMENTS			
Flores & Associates		\$ 20,401.60	RUN DATE 1/3/2023

ACCOUNTS PAYABLE CHECKS



P.O. NO.	VENDOR NO.	VENDOR NAME	INVOICE NO.	INVOICE DATE	A/P ACRL	ACCOUNT NO.	NET AMOUNT	CHECK NO.	ACH PMT	G/L ACCOUNT DESC.	BATCH INV. DESCRIPTION
00000000	001960	ACI PAYMENTS, INC.	1000083634	12/13/2022		4100-041100-1292-411-410	4,927.64	224007		Bank/CC & Other Fees	01854 # 39343
			CHECK TOTAL	4,927.64						TOTAL	4,927.64
00000000	000010	BANK OF SOUTHSIDE VA	0107 1222 01	11/14/2022		4100-051500-1246-551-510	43.18	224008		Food Supplies	01854 JAIL ACCT
00000000	000010		0107 1222 02	11/14/2022		4100-051500-1246-551-510	34.88	224008		Food Supplies	01854 JAIL ACCT
00000000	000010		0107 1222 03	11/16/2022		4100-051500-1246-551-510	50.00	224008		Food Supplies	01854 JAIL ACCT
00000000	000010		0107 1222 04	11/20/2022		4100-051500-1246-551-510	10.97	224008		Food Supplies	01854 JAIL ACCT
00000000	000010		0107 1222 05	11/27/2022		4100-051500-1246-551-510	50.00	224008		Food Supplies	01854 JAIL ACCT
00000000	000010		0107 1222 06	12/01/2022		4100-051500-1259-551-510	210.56	224008		Other Equipment Purchases	01854 JAIL ACCT
00000000	000010		0107 1222 07	12/01/2022		4100-051500-1259-551-510	494.88	224008		Other Equipment Purchases	01854 JAIL ACCT
00000000	000010		0107 1222 08	12/07/2022		4100-051500-1246-551-510	50.00	224008		Food Supplies	01854 JAIL ACCT
			CHECK TOTAL	944.47						TOTAL	944.47
00000000	000738	BUTLER'S TOWING AND	12241	12/29/2022		4100-051100-1265-512-510	97.50	224009		Vehicle Maintenance & Repairs	01854 SUSSEX SHERIFF
00000000	000738		12266	1/02/2023		4100-051100-1265-512-510	20.00	224009		Vehicle Maintenance & Repairs	01854 SUSSEX SHERIFF
00000000	000738		12267	1/02/2023		4100-051100-1265-519-510	46.70	224009		Vehicle Maintenance Repairs	01854 SUSSEX SHERIFF
			CHECK TOTAL	164.20						TOTAL	164.20
00000000	000728	CARQUEST OF WAKEFIELD	15335-41412	12/28/2022		4100-051100-1265-512-510	308.70	224010		Vehicle Maintenance & Repairs	01854 # 5001
			CHECK TOTAL	308.70						TOTAL	308.70
00000000	001630	CHENEY BROTHERS	12-923922640	12/28/2022		4100-051500-1246-551-510	2,352.52	224011		Food Supplies	01854 # 60030700
			CHECK TOTAL	2,352.52						TOTAL	2,352.52
00000000	001946	COMMONWEALTH OCCUPATIONAL	952133	12/05/2022		4100-021100-1227-211-210	485.00	224012		Medical Services	01854 SUSSEX COUNTY
			CHECK TOTAL	485.00						TOTAL	485.00
00000000	000845	CROWN CASTLE GT COMPANY	399993997	1/01/2023		4100-021500-1252-253-210	1,382.35	224013		Equipment Lease/Rental	01854 # 106663
			CHECK TOTAL	1,382.35						TOTAL	1,382.35
00000000	000871	CRYSTAL SPRINGS	6091788 120822	12/08/2022		4100-062100-1277-621-620	40.98	224014		Water Services	01854 # 11421076091788
			CHECK TOTAL	40.98						TOTAL	40.98
00000000	001613	CUSTOM CLEANERS	12157	12/30/2022		4100-051100-1244-512-510	16.00	224015		Uniform Services	01854 SUSSEX SHERIFF
00000000	001613		12158	12/30/2022		4100-051500-1244-551-510	104.00	224015		Uniform Services	01854 SUSSEX SHERIFF
			CHECK TOTAL	120.00						TOTAL	120.00
00000000	001651	DOCUMENT SYSTEMS	127376	12/09/2022		4100-062100-1252-621-620	46.15	224016		Equipment Lease/Rental	01854 # SC07
			CHECK TOTAL	46.15						TOTAL	46.15
00000000	999999	DRIVEERT	1016847872	11/19/2022		4100-051100-1265-512-510	5.81	224017		Vehicle Maintenance & Repairs	01854 # 6797564
			CHECK TOTAL	5.81						TOTAL	5.81
00000000	001605	GLOBAL SIGNAL ACQUISITIONS	40077633	1/01/2023		4100-021500-1252-253-210	477.82	224018		Equipment Lease/Rental	01854 # 393860
			CHECK TOTAL	477.82						TOTAL	477.82
00000000	001703	HEFTY WILEY & GORE P.C.	12168	12/25/2022		4100-022100-1223-281-220	8,500.00	224019		Legal Services	01854 SUSSEX COUNTY
			CHECK TOTAL	8,500.00						TOTAL	8,500.00
00000000	001115	LIFESTAR AMBULANCE	SC112022	12/12/2022		4100-021500-2110-252-210-524	21,888.00	224020		Emergency Med. SVC - Pd EMT.	01854 NOVEMBER 2022
00000000	001115		WAV112022	12/12/2022		4100-021500-2110-252-210-524	51,840.00	224020		Emergency Med. SVC - Pd EMT.	01854 NOVEMBER 2022
			CHECK TOTAL				21,888.00	224020			
			CHECK TOTAL				51,840.00	224020			

P.O. NO.	VENDOR NO.	VENDOR NAME	INVOICE NO.	INVOICE DATE	A/P ACCRL	ACCOUNT NO.	NET AMOUNT	CHECK NO.	ACH PMT	G/L ACCOUNT DESC.	BATCH INV DESCRIPTION
0000000	001115		WT112022	12/12/2022		4100-021500-2110-252-210-524	27,000.00	224020		Emergency Med. SVC - Pd EMT.	01854 SUSSEX PUBLIC SAFE
	DISC. TOTAL	.00	CHECK TOTAL	100,728.00		.00 CPA PMT TOTAL	.00	EPY PMT TOTAL			100,728.00
0000000	001943	MARK D. MILITANA MD PC	DECEMBER 2022	9/28/2022		4100-051500-1293-551-510	3,750.00	224021		Inmate Medical Expenses	01854 SUSSEX SHERIFF
	DISC. TOTAL	.00	CHECK TOTAL	3,750.00		.00 CPA PMT TOTAL	.00	EPY PMT TOTAL			3,750.00
0000000	002066	MESSIER, SAREESE	SM 010323	1/03/2023		4100-023100-1241-291-230	395.16	224022		Office Supplies	01854 REIMBURSEMENT
	DISC. TOTAL	.00	CHECK TOTAL	591.10		.00 CPA PMT TOTAL	.00	EPY PMT TOTAL			591.10
0000000	000991	PARKER OIL CO	387885	12/27/2022		4100-051500-1278-551-510	1,818.58	224023		Oil	01854 # 87746E-1
	DISC. TOTAL	.00	CHECK TOTAL	1,818.58		.00 CPA PMT TOTAL	.00	EPY PMT TOTAL			1,818.58
0000000	000165	POSTMASTER	REGISTRAR 010323	1/03/2023		4100-023100-1231-291-230	24.00	224024		Postage	01854 POSTAGE
	DISC. TOTAL	.00	CHECK TOTAL	8003071332		.00 CPA PMT TOTAL	253.59	224025		Contractual Services	01854 # 1000528107
	DISC. TOTAL	.00	CHECK TOTAL	7367830668-0-1		.00 CPA PMT TOTAL	138.02	224026		Office Supplies	01854 # 27065688
	DISC. TOTAL	.00	CHECK TOTAL	7367830668-0-2		.00 CPA PMT TOTAL	23.99	224026		Office Supplies	01854 # 27065688
	DISC. TOTAL	.00	CHECK TOTAL	7368489238-0-1		.00 CPA PMT TOTAL	175.70	224026		Office Supplies	01854 # 27065688
	DISC. TOTAL	.00	CHECK TOTAL	7368753851-0-1		.00 CPA PMT TOTAL	128.02	224026		Office Supplies	01854 # 27065688
	DISC. TOTAL	.00	CHECK TOTAL	7368753851-0-2		.00 CPA PMT TOTAL	7.16	224026		Office Supplies	01854 # 27065688
	DISC. TOTAL	.00	CHECK TOTAL	7368753851-0-3		.00 CPA PMT TOTAL	227.35	224026		Office Supplies	01854 # 27065688
	DISC. TOTAL	.00	CHECK TOTAL	7368776754-0-1		.00 CPA PMT TOTAL	13.99	224026		Office Supplies	01854 # 27065688
	DISC. TOTAL	.00	CHECK TOTAL	7368776754-0-2		.00 CPA PMT TOTAL	46.31	224026		Office Supplies	01854 # 27065688
	DISC. TOTAL	.00	CHECK TOTAL	7368776754-0-3		.00 CPA PMT TOTAL	305.66	224026		Office Supplies	01854 # 27065688
	DISC. TOTAL	.00	CHECK TOTAL	7369641458-0-1		.00 CPA PMT TOTAL	.00	EPY PMT TOTAL			1,074.19
0000000	001975	STAPLES, INC.	7370398544-0-1	12/13/2022		4100-021100-1241-211-210	218.35	224027		Office Supplies	01854 # 27065688
	DISC. TOTAL	.00	CHECK TOTAL	7371166174-0-1		.00 CPA PMT TOTAL	50.57	224027		Office Supplies	01854 # 27065688
	DISC. TOTAL	.00	CHECK TOTAL	7371248925-0-1		.00 CPA PMT TOTAL	75.53	224027		Office Supplies	01854 # 27065688
	DISC. TOTAL	.00	CHECK TOTAL	7602416134-0-1		.00 CPA PMT TOTAL	234.17	224027		Office Supplies	01854 # 27065688
	DISC. TOTAL	.00	CHECK TOTAL	0143958-002		.00 CPA PMT TOTAL	143.89	224028		Office Supplies	01854 # SYCC-0
	DISC. TOTAL	.00	CHECK TOTAL	0144093-001		.00 CPA PMT TOTAL	76.12	224028		Office Supplies	01854 # SKCWAT-0
	DISC. TOTAL	.00	CHECK TOTAL	2353 1222 01		.00 CPA PMT TOTAL	38.28	224029		Meals	01854 # 4046011199882353
	DISC. TOTAL	.00	CHECK TOTAL	2353 1222 02		.00 CPA PMT TOTAL	351.78	224029		Lodging	01854 # 4046011199882353
	DISC. TOTAL	.00	CHECK TOTAL	2353 1222 03		.00 CPA PMT TOTAL	.00	EPY PMT TOTAL			741.84
	DISC. TOTAL	.00	CHECK TOTAL	0756733346 0622		.00 CPA PMT TOTAL	88.29	224030		Telecommunications	01854 # 351337100000174
	DISC. TOTAL	.00	CHECK TOTAL	0756733346 0622		.00 CPA PMT TOTAL	517.37	224030		Telecommunications	01854 # 351337100000174
	DISC. TOTAL	.00	CHECK TOTAL	0756733346 0722		.00 CPA PMT TOTAL	90.39	224030		Telecommunications	01854 # 351337100000174
	DISC. TOTAL	.00	CHECK TOTAL	0756733346 0722		.00 CPA PMT TOTAL	524.74	224030		Telecommunications	01854 # 351337100000174

P.O. NO.	VENDOR NO.	VENDOR NAME	INVOICE NO.	INVOICE DATE	A/P ACRL	ACCOUNT NO.	NET AMOUNT	CHECK NO.	ACH PMT	G/L ACCOUNT DESC.	BATCH INV DESCRIPTION
0000000	000769		0756733346	0822		4100-051500-1234-551-510	90.33	224030		Telecommunications	01854 # 351337100000174
0000000	000769		0756733346	0822		4100-051100-1234-512-510	523.60	224030		Telecommunications	01854 # 351337100000174
0000000	000769		0756733346	0822		4100-021700-1234-271-210	9.00	224030		Telecommunications	01854 # 351337100000174
0000000	000769		0756733346	0922		4100-051500-1234-551-510	90.33	224030		Telecommunications	01854 # 351337100000174
0000000	000769		0756733346	0922		4100-051100-1234-512-510	523.60	224030		Telecommunications	01854 # 351337100000174
0000000	000769		0756733346	0922		4100-021700-1234-271-210	18.31	224030		Telecommunications	01854 # 351337100000174
0000000	000769		0756733346	0922		4100-051500-1234-551-510	89.61	224030		Telecommunications	01854 # 351337100000174
0000000	000769		0756733346	1022		4100-051100-1234-512-510	520.18	224030		Telecommunications	01854 # 351337100000174
0000000	000769		0756733346	1022		4100-021700-1234-271-210	27.52	224030		Telecommunications	01854 # 351337100000174
0000000	000769		0756733346	1122		4100-051500-1234-551-510	89.61	224030		Telecommunications	01854 # 351337100000174
0000000	000769		0756733346	1122		4100-051100-1234-512-510	520.14	224030		Telecommunications	01854 # 351337100000174
0000000	000769		0756733346	1122		4100-021700-1234-271-210	36.73	224030		Telecommunications	01854 # 351337100000174
0000000	000769		0756733346	1222		4100-051500-1234-551-510	89.61	224030		Telecommunications	01854 # 351337100000174
0000000	000769		0756733346	1222		4100-051100-1234-512-510	520.14	224030		Telecommunications	01854 # 351337100000174
0000000	000769		0756733346	1222		4100-021700-1234-271-210	45.88	224030		Telecommunications	01854 # 351337100000174
			CHECK TOTAL	4,415.46		.00 CPA PMT TOTAL	.00	EPY PMT TOTAL		TOTAL	4,415.46
0000000	000757	VERIZON BUSINESS	7033892	12/10/2022		4100-021600-1234-263-210	431.66	224031		Telecommunications	01854 # Y2694822
			CHECK TOTAL	431.66		.00 CPA PMT TOTAL	.00	EPY PMT TOTAL		TOTAL	431.66
0000000	000039	VERIZON WIRELESS	9923355434	12/19/2022		4100-021600-1234-263-210	2,995.25	224032		Telecommunications	01854 # 742284843-00001
			CHECK TOTAL	2,995.25		.00 CPA PMT TOTAL	.00	EPY PMT TOTAL		TOTAL	2,995.25
0000000	001365	WILLIAM COLLIE	CBM 010423	1/04/2023		4100-062100-1254-621-620	50.00	224033		Equipment Maintenance	01854 SUSSEX CIRCUIT COU
0000000	001365		CBM 121222	12/12/2022		4100-062100-1254-621-620	50.00	224033		Equipment Maintenance	01854 SUSSEX CIRCUIT COU
			CHECK TOTAL	100.00		.00 CPA PMT TOTAL	.00	EPY PMT TOTAL		TOTAL	100.00
0000000	000879	WOMACK PUBLISHING CO	83325	9/28/2022		4100-021100-1235-211-210	305.96	224034		Advertising	01854 # 5449
			CHECK TOTAL	305.96		.00 CPA PMT TOTAL	.00	EPY PMT TOTAL		TOTAL	305.96
0000000	001915	WYATT, KELLI D.	KDW 122922	12/29/2022		4100-063100-1264-632-630	137.06	224035		Gasoline/Mileage-Non Reimbursement	01854 # 137.06
			CHECK TOTAL	137.06		.00 CPA PMT TOTAL	.00	EPY PMT TOTAL		TOTAL	137.06
0000000	001644	XEROX FINANCIAL SERVICES	3663559	10/12/2022		4100-062100-1252-621-620	149.63	224036		Equipment Lease/Rental	01854 # 0200128117001
			CHECK TOTAL	149.63		.00 CPA PMT TOTAL	.00	EPY PMT TOTAL		TOTAL	149.63
0000000	000010	BANK OF SOUTHSIDE VA	0255 1222 01	11/16/2022		4100-051500-1247-551-510	24.22	224037		Janitorial Supplies	01854 SHERIFF ACCT
0000000	000010		0255 1222 02	11/17/2022		4100-051100-1241-512-510	28.98	224037		Office Supplies	01854 SHERIFF ACCT
0000000	000010		0255 1222 03	11/18/2022		4100-051100-1241-512-510	84.22	224037		Office Supplies	01854 SHERIFF ACCT
0000000	000010		0255 1222 04	11/30/2022		4100-051100-1241-512-510	29.99	224037		Office Supplies	01854 SHERIFF ACCT
			CHECK TOTAL	167.41		.00 CPA PMT TOTAL	.00	EPY PMT TOTAL		TOTAL	167.41
0000000	000769	VERIZON	0973062717	1222		4100-021100-1234-211-210	214.10	224038		Telecommunications	01854 # 951295778000179
0000000	000769		0973062717	1222		4100-021400-1234-241-210	47.58	224038		Telecommunications	01854 # 951295778000179
0000000	000769		0973062717	1222		4100-021400-1234-242-210	71.37	224038		Telecommunications	01854 # 951295778000179
0000000	000769		0973062717	1222		4100-021600-1234-261-210	23.79	224038		Telecommunications	01854 # 951295778000179
0000000	000769		0973062717	1222		4100-021500-1234-253-210	23.79	224038		Telecommunications	01854 # 951295778000179
0000000	000769		0973062717	1222		4100-023100-1234-291-230	71.37	224038		Telecommunications	01854 # 951295778000179
0000000	000769		0973062717	1222		4100-041100-1234-411-410	95.15	224038		Telecommunications	01854 # 951295778000179
0000000	000769		0973062717	1222		4100-031100-1234-311-310	95.15	224038		Telecommunications	01854 # 951295778000179
0000000	000769		0973062717	1222		4100-063100-1234-631-630	118.94	224038		Telecommunications	01854 # 951295778000179

P.O. NO.	VENDOR NO.	VENDOR NAME	INVOICE NO.	INVOICE DATE	A/P ACCR	ACCOUNT NO.	NET AMOUNT	CHECK NO.	ACH PMT	G/L ACCOUNT DESC.	BATCH INV. DESCRIPTION
0000000	000769	VERIZON	0973062717	12/27/2022		4100-062100-1234-621-620	142.73	224038		Telecommunications	01854 # 951295778000179
0000000	000769		0973062717	12/27/2022		4100-063100-1234-632-630	23.79	224038		Telecommunications	01854 # 951295778000179
0000000	000769		0973062717	12/27/2022		4105-071100-1234-711-710	642.29	224038		Telecommunications	01854 # 951295778000179
		DISC. TOTAL					.00	EPY PMT TOTAL			1,570.05
0000000	000769	VERIZON	0695890348	0922	9/30/2022	4100-051100-1234-516-510	314.13	224039		Telecommunications	01854 # 351333549000198
0000000	000769		0695890348	1022	10/31/2022	4100-051100-1234-516-510	314.13	224039		Telecommunications	01854 # 351333549000198
0000000	000769		0695890348	1122	11/30/2022	4100-051100-1234-516-510	319.13	224039		Telecommunications	01854 # 351333549000198
0000000	000769		0695890348	1222	12/31/2022	4100-051100-1234-516-510	324.23	224039		Telecommunications	01854 # 351333549000198
		DISC. TOTAL					.00	EPY PMT TOTAL			1,271.62
		CHECK TOTAL					.00	EPY PMT TOTAL			141,079.67
		CHECK TOTAL					.00	EPY PMT TOTAL			141,079.67

I HEREBY APPROVE THIS REGISTER FOR PAYMENT WITH EXCEPTIONS LISTED BELOW OR PREVIOUSLY DOCUMENTED.
 THE TOTAL 141,079.67 - EQUALS THE WEEKLY LOG SHEET TOTALS AS ADJUSTED.

1-5-23
 DATE

1-5-23
 DATE

1/5/23
 DATE

[Signature]
 DIRECTOR OF FINANCE

[Signature]
 COUNTY ADMINISTRATOR

[Signature]
 DESTE J. COX, TREASURER

P.O. NO.	VENDOR NO.	VENDOR NAME	INVOICE NO.	INVOICE DATE	A/P ACCRL	ACCOUNT NO.	NET AMOUNT	CHECK NO.	ACH PMT	G/L ACCOUNT DESC.	BATCH INV. DESCRIPTION
0000000	000024	CRATER YOUTH CARE	23040	12/27/2022		4100-081800-2110-863-810	7,402.08	224070	.00	Crater Youth Care Commission	01856 # 7,402.08
0000000	000871	CRYSTAL SPRINGS	1352055	1/05/2023		4100-061100-1277-612-610	90.93	224071	.00	Water Services	01856 # 90.93
0000000	000193	DEPART OF MOTOR VEHICLES	202236500573	1/09/2023		4100-041100-1259-411-410	475.00	224072	.00	Misc.Oth-DMV Stops	01856 # 475.00
0000000	001892	DIRECTV,LLC	34959122X221210	12/10/2022		4100-021500-1234-253-210	120.34	224073	.00	Telecommunications	01856 # 120.34
0000000	000902	DOC FARMER'S MARKET	MKT97123	1/03/2023		4100-051500-1246-551-510	200.80	224074	.00	Food Supplies	01856 SUSSEX COUNTY JAIL
0000000	001651	DOCUMENT SYSTEMS	123311	6/01/2022		4100-031100-1225-312-310	112.82	224075	.00	Management Consulting Service	01856 # SC10
0000000	001651	DOCUMENT SYSTEMS	123545	6/13/2022		4100-021600-1252-262-210	24.99	224075	.00	Equipment Lease/Rental	01856 # SC09
0000000	001651	DOCUMENT SYSTEMS	124111	7/06/2022		4100-021600-1252-262-210	25.63	224075	.00	Equipment Lease/Rental	01856 # SC09
0000000	001651	DOCUMENT SYSTEMS	124618	8/02/2022		4100-031100-1225-312-310	56.70	224075	.00	Management Consulting Service	01856 # SC10
0000000	001651	DOCUMENT SYSTEMS	124695	8/12/2022		4100-021600-1252-262-210	24.99	224075	.00	Equipment Lease/Rental	01856 # SC09
0000000	001651	DOCUMENT SYSTEMS	124835	8/12/2022		4100-021500-1252-263-210	49.00	224075	.00	Equipment Lease/Rental	01856 # SC14
0000000	001651	DOCUMENT SYSTEMS	125314	9/02/2022		4100-021500-1252-263-210	49.00	224075	.00	Equipment Lease/Rental	01856 # SC14
0000000	001651	DOCUMENT SYSTEMS	125433	9/07/2022		4100-021600-1252-262-210	24.99	224075	.00	Equipment Lease/Rental	01856 # SC09
0000000	001651	DOCUMENT SYSTEMS	126050	10/08/2022		4100-021600-1252-262-210	24.99	224075	.00	Equipment Lease/Rental	01856 # SC09
0000000	001651	DOCUMENT SYSTEMS	127857	1/04/2023		4100-041100-1255-411-410	127.30	224075	.00	Maintenance Service Contract	01856 # SC05-001
0000000	001651	DOCUMENT SYSTEMS	127858	1/04/2023		4100-041100-1255-411-410	24.41	224076	.00	Maintenance Service Contract	01856 # SC05-001
0000000	001651	DOCUMENT SYSTEMS	127859	1/04/2023		4100-021100-1252-211-210	878.41	224076	.00	Equipment Lease/Rental	01856 # SC05-002
0000000	001651	DOCUMENT SYSTEMS	127860	1/04/2023		4100-021100-1255-211-210	126.53	224076	.00	Maintenance Service Contract	01856 # SC05-003
0000000	001651	DOCUMENT SYSTEMS	127862	1/04/2023		4100-031100-1225-312-310	63.81	224076	.00	Management Consulting Service	01856 # SC10
0000000	000084	DOMINION VIRGINIA POWER	0482572328	12/28/2022		4100-021600-1276-263-210	3,263.25	224077	.00	Electric	01856 # 0482572328
0000000	000084	DOMINION VIRGINIA POWER	5080737736	12/28/2022		4100-021600-1276-263-210	90.20	224077	.00	Electric	01856 # 5080737736
0000000	000084	DOMINION VIRGINIA POWER	9447701492	12/27/2022		4100-021600-1276-263-210	18.92	224077	.00	Electric	01856 # 9447701492
0000000	000276	GREENSVILLE COUNTY WATER	1175 012023	1/20/2023		4100-021600-1277-263-210	61.16	224078	.00	Water Services	01856 # 1175
0000000	001788	HALE'S ELECTRIC SERVICE	H21018941	1/07/2023		4100-021500-1254-253-210	545.95	224079	.00	Equipment Maintenance	01856 SUSSEX PUBLIC SAFE
0000000	001747	HERC RENTALS, INC.	32571672-015	1/02/2023		4100-021600-1252-264-210	1,016.83	224080	.00	Equipment Lease/Rental	01856 # 3041262
0000000	001685	HICKS, RONALD W. SR.	RWH 010923	1/09/2023		4100-023100-1264-291-230	312.06	224081	.00	Gasoline/Mileage-Non Training	01856 MILEAGE
0000000	000049	JARRATT HARDWARE	2212-143146	12/27/2022		4100-051500-1272-551-510	21.56	224082	.00	Building Maintenance & Repair	01856 # 159

AP100 1/12/2023 SUSSEX COUNTY A/P CHECK REGISTER TIME-12:03:06 ActPd - 2023/01

P.O. NO.	VENDOR NO.	VENDOR NAME	INVOICE NO.	INVOICE DATE	A/P ACCRL	ACCOUNT NO.	NET AMOUNT	CHECK NO.	ACH PMT	G/L ACCOUNT DESC.	BATCH INV. DESCRIPTION
0000000	000049		2212-143296	12/28/2022		4100-051500-1272-551-510	8.59	224082		Building Maintenance & Repair	01856 # 159
0000000	000049		2212-143492	12/29/2022		4100-051500-1272-551-510	8.99	224082		Building Maintenance & Repair	01856 # 159
	DISC. TOTAL			39.14	ACH PMT TOTAL		.00	EPY PMT TOTAL		TOTAL	39.14
0000000	001550	KINEX NETWORKING SOLUTION	2212-0012369	12/19/2022		4100-021600-1234-263-210	1.350	224083		Telecommunications	01856 # SUB-2201-0000487
	DISC. TOTAL			1.350	ACH PMT TOTAL		.00	EPY PMT TOTAL		TOTAL	1.350
0000000	002100	LETS CORP	INV-001562	1/03/2023		4100-051100-1229-512-510	1.787	224084		Other Professional Services	01856 SUSSEX SHERIFF
	DISC. TOTAL			1.787	ACH PMT TOTAL		.00	EPY PMT TOTAL		TOTAL	1.787
0000000	001046	MCI	4342465511	11/13/2022		4100-021600-1234-263-210	83.65	224085		Telecommunications	01856 # 8692925192
	DISC. TOTAL			83.65	ACH PMT TOTAL		.00	EPY PMT TOTAL		TOTAL	83.65
0000000	001983	MID-ATLANTIC PEST AND LAW	3578	1/01/2023		4100-021200-1274-221-210	440.00	224086		Grounds Maintenance & Repairs	01856 SUSSEX COUNTY
0000000	001983		3579	1/01/2023		4100-021600-1274-264-210	320.00	224086		Grounds Maintenance & Repairs	01856 SUSSEX COUNTY
	DISC. TOTAL			760.00	ACH PMT TOTAL		.00	EPY PMT TOTAL		TOTAL	760.00
0000000	000550	OCBURN SIGN CO. LLC	OP6084	12/26/2022		4100-021200-1272-221-210-602	90.00	224087		DMW-Select ADA Compliance	01856 SUSSEX COUNTY
	DISC. TOTAL			90.00	ACH PMT TOTAL		.00	EPY PMT TOTAL		TOTAL	90.00
0000000	001141	PARHAM'S WELDING &	42391	11/21/2022		4100-021200-1254-221-210	144.38	224088		Equipment Maintenance	01856 SUSSEX COUNTY
	DISC. TOTAL			144.38	ACH PMT TOTAL		.00	EPY PMT TOTAL		TOTAL	144.38
0000000	001246	PHILLIPS TELECOMMUNICATIONS	33110	12/30/2022		4100-021600-1234-263-210	492.50	224089		Telecommunications	01856 SUSSEX COUNTY
	DISC. TOTAL			492.50	ACH PMT TOTAL		.00	EPY PMT TOTAL		TOTAL	492.50
0000000	000061	PRINCE GEORGE ELECTRIC	1413003200	12/28/2022		4100-021600-1276-263-210	55.39	224090		Electric	01856 # 1413003200
0000000	000061		1423010000	12/28/2022		4100-021600-1276-263-210	89.61	224090		Electric	01856 # 1423010000
0000000	000061		1667000200	12/28/2022		4100-021600-1276-263-210	62.27	224090		Electric	01856 # 1667000200
	DISC. TOTAL			207.27	ACH PMT TOTAL		.00	EPY PMT TOTAL		TOTAL	207.27
0000000	002083	READ'S UNIFORMS INC.	153143-99	11/11/2022		4100-051500-1244-551-510	129.24	224091		Uniform Services	01856 # 16956-99
0000000	002083		153145-99	11/11/2022		4100-051100-1244-512-510	11.00	224091		Uniform Services	01856 # 16956-99
0000000	002083		153146-99	11/11/2022		4100-051100-1244-512-510	166.80	224091		Uniform Services	01856 # 16956-99
0000000	002083		153147-99	11/11/2022		4100-051100-1244-512-510	117.48	224091		Uniform Services	01856 # 16956-99
0000000	002083		153151-99	11/11/2022		4100-051100-1244-512-510	117.48	224091		Uniform Services	01856 # 16956-99
0000000	002083		153152-99	11/11/2022		4100-051100-1244-512-510	117.48	224091		Uniform Services	01856 # 16956-99
0000000	002083		153153-99	11/11/2022		4100-051100-1244-512-510	117.48	224091		Uniform Services	01856 # 16956-99
0000000	002083		153161-99	11/11/2022		4100-051500-1244-551-510	117.48	224091		Uniform Services	01856 # 16956-99
0000000	002083		153168-99	11/11/2022		4100-051100-1244-512-510	117.48	224091		Uniform Services	01856 # 16956-99
0000000	002083		153170-99	11/11/2022		4100-051100-1244-512-510	117.48	224091		Uniform Services	01856 # 16956-99
	DISC. TOTAL			1.129	ACH PMT TOTAL		.00	EPY PMT TOTAL		TOTAL	1.129
0000000	002083	READ'S UNIFORMS INC.	153171-99	11/11/2022		4100-051500-1244-551-510	117.48	224092		Uniform Services	01856 # 16956-99
0000000	002083		153174-99	11/11/2022		4100-051500-1244-551-510	117.48	224092		Uniform Services	01856 # 16956-99
0000000	002083		153177-99	11/11/2022		4100-051100-1244-512-510	64.62	224092		Uniform Services	01856 # 16956-99
0000000	002083		153179-99	11/11/2022		4100-051100-1244-512-510	64.62	224092		Uniform Services	01856 # 16956-99
0000000	002083		153181-99	11/11/2022		4100-051100-1244-512-510	117.48	224092		Uniform Services	01856 # 16956-99
0000000	002083		153188-99	11/11/2022		4100-051500-1244-551-510	117.48	224092		Uniform Services	01856 # 16956-99
0000000	002083		153191-99	11/11/2022		4100-051500-1244-551-510	117.48	224092		Uniform Services	01856 # 16956-99
0000000	002083		153193-99	11/11/2022		4100-051100-1244-512-510	117.48	224092		Uniform Services	01856 # 16956-99

P.O. NO.	VENDOR NO.	VENDOR NAME	INVOICE NO.	INVOICE DATE	A/P ACCRL	ACCOUNT NO.	NET AMOUNT	CHECK NO.	ACH PMT	G/L ACCOUNT DESC.	BATCH INV. DESCRIPTION
000000	002083	.00	153196-99	11/11/2022		4100-051100-1244-512-510	117.48	224092		Uniform Services	01856 # 16956-99
000000	002083		153199-99	11/11/2022		4100-051100-1244-512-510	117.48	224092		Uniform Services	01856 # 16956-99
	DISC. TOTAL		CHECK TOTAL	1.069.08	ACH PMT TOTAL	.00 CPA PMT TOTAL	.00	EPY PMT TOTAL			1.069.08
000000	002083	READ'S UNIFORMS INC.	157289-99	12/02/2022		4100-051100-1244-512-510	700.96	224093		Uniform Services	01856 # 16956-99
000000	002083		157629-99	12/05/2022		4100-051500-1244-551-510	93.42	224093		Uniform Services	01856 # 16956-99
000000	002083		157631-99	12/05/2022		4100-051100-1244-519-510	93.42	224093		Uniform Services	01856 # 16956-99
000000	002083		157632-99	12/05/2022		4100-051100-1244-512-510	93.42	224093		Uniform Services	01856 # 16956-99
000000	002083		157633-99	12/05/2022		4100-051100-1244-512-510	46.71	224093		Uniform Services	01856 # 16956-99
000000	002083		157635-99	12/05/2022		4100-051100-1244-512-510	93.42	224093		Uniform Services	01856 # 16956-99
000000	002083		157636-99	12/05/2022		4100-051100-1244-515-510	161.55	224093		Uniform Services	01856 # 16956-99
000000	002083		157638-99	12/05/2022		4100-051100-1244-519-510	161.55	224093		Uniform Services	01856 # 16956-99
000000	002083		157639-99	12/05/2022		4100-051500-1244-551-510	93.42	224093		Uniform Services	01856 # 16956-99
000000	002083		157640-99	12/05/2022		4100-051500-1244-551-510	121.44	224093		Uniform Services	01856 # 16956-99
	DISC. TOTAL		CHECK TOTAL	1.659.31	ACH PMT TOTAL	.00 CPA PMT TOTAL	.00	EPY PMT TOTAL			1.659.31
000000	002083	READ'S UNIFORMS INC.	157641-99	12/05/2022		4100-051100-1244-512-510	121.44	224094		Uniform Services	01856 # 16956-99
000000	002083		157642-99	12/05/2022		4100-051100-1244-519-510	46.71	224094		Uniform Services	01856 # 16956-99
000000	002083		157644-99	12/05/2022		4100-051500-1244-551-510	93.42	224094		Uniform Services	01856 # 16956-99
000000	002083		157645-99	12/05/2022		4100-051500-1244-551-510	93.42	224094		Uniform Services	01856 # 16956-99
000000	002083		157647-99	12/05/2022		4100-051500-1244-551-510	93.42	224094		Uniform Services	01856 # 16956-99
000000	002083		157652-99	12/05/2022		4100-051500-1244-551-510	93.42	224094		Uniform Services	01856 # 16956-99
000000	002083		157653-99	12/05/2022		4100-051100-1244-512-510	93.42	224094		Uniform Services	01856 # 16956-99
000000	002083		157654-99	12/05/2022		4100-051100-1244-512-510	93.42	224094		Uniform Services	01856 # 16956-99
000000	002083		157655-99	12/05/2022		4100-051100-1244-512-510	93.42	224094		Uniform Services	01856 # 16956-99
000000	002083		157657-99	12/05/2022		4100-051100-1244-512-510	93.42	224094		Uniform Services	01856 # 16956-99
	DISC. TOTAL		CHECK TOTAL	915.51	ACH PMT TOTAL	.00 CPA PMT TOTAL	.00	EPY PMT TOTAL			915.51
000000	002083	READ'S UNIFORMS INC.	157661-99	12/05/2022		4100-051500-1244-551-510	93.42	224095		Uniform Services	01856 # 16956-99
000000	002083		157668-99	12/05/2022		4100-051100-1244-512-510	93.42	224095		Uniform Services	01856 # 16956-99
000000	002083		157689-99	12/05/2022		4100-051100-1244-512-510	121.44	224095		Uniform Services	01856 # 16956-99
000000	002083		157692-99	12/05/2022		4100-051500-1244-551-510	93.42	224095		Uniform Services	01856 # 16956-99
000000	002083		157696-99	12/05/2022		4100-051100-1244-512-510	93.42	224095		Uniform Services	01856 # 16956-99
000000	002083		157698-99	12/05/2022		4100-051100-1244-512-510	93.42	224095		Uniform Services	01856 # 16956-99
000000	002083		157700-99	12/05/2022		4100-051500-1244-551-510	93.42	224095		Uniform Services	01856 # 16956-99
000000	002083		157701-99	12/05/2022		4100-051100-1244-512-510	93.42	224095		Uniform Services	01856 # 16956-99
000000	002083		157702-99	12/05/2022		4100-051100-1244-519-510	117.48	224095		Uniform Services	01856 # 16956-99
000000	002083		157703-99	12/05/2022		4100-051500-1244-551-510	117.48	224095		Uniform Services	01856 # 16956-99
	DISC. TOTAL		CHECK TOTAL	1.010.34	ACH PMT TOTAL	.00 CPA PMT TOTAL	.00	EPY PMT TOTAL			1.010.34
000000	002083	READ'S UNIFORMS INC.	157704-99	12/05/2022		4100-051100-1244-512-510	117.48	224096		Uniform Services	01856 # 16956-99
000000	002083		157705-99	12/05/2022		4100-051500-1244-551-510	64.62	224096		Uniform Services	01856 # 16956-99
000000	002083		157706-99	12/05/2022		4100-051500-1244-551-510	64.62	224096		Uniform Services	01856 # 16956-99
000000	002083		157708-99	12/05/2022		4100-051100-1244-512-510	64.62	224096		Uniform Services	01856 # 16956-99
000000	002083		157710-99	12/05/2022		4100-051100-1244-512-510	117.48	224096		Uniform Services	01856 # 16956-99
000000	002083		157711-99	12/05/2022		4100-051100-1244-519-510	64.62	224096		Uniform Services	01856 # 16956-99
000000	002083		157712-99	12/05/2022		4100-051500-1244-551-510	129.24	224096		Uniform Services	01856 # 16956-99
000000	002083		157713-99	12/05/2022		4100-051500-1244-551-510	117.48	224096		Uniform Services	01856 # 16956-99
000000	002083		157715-99	12/05/2022		4100-051100-1244-512-510	64.62	224096		Uniform Services	01856 # 16956-99
000000	002083		157716-99	12/05/2022		4100-051100-1244-519-510	117.48	224096		Uniform Services	01856 # 16956-99
	DISC. TOTAL		CHECK TOTAL	922.26	ACH PMT TOTAL	.00 CPA PMT TOTAL	.00	EPY PMT TOTAL			922.26

AP100 1/12/2023 SUSSEX COUNTY A/P CHECK REGISTER TIME-12:03:06 ActPd - 2023/01

P.O. NO.	VENDOR NO.	VENDOR NAME	INVOICE NO	INVOICE DATE	A/P ACRL	ACCOUNT NO.	NET AMOUNT	CHECK NO.	ACH PMT	G/L ACCOUNT DESC.	BATCH INV. DESCRIPTION
0000000	002083	READ'S UNIFORMS INC.	157717-99	12/05/2022		4100-051100-1244-512-510	64.62	224097		Uniform Services	01856 # 16956-99
0000000	002083		157718-99	12/05/2022		4100-051500-1244-551-510	129.24	224097		Uniform Services	01856 # 16956-99
0000000	002083		157719-99	12/05/2022		4100-051100-1244-512-510	64.62	224097		Uniform Services	01856 # 16956-99
0000000	002083		157720-99	12/05/2022		4100-051100-1244-512-510	64.62	224097		Uniform Services	01856 # 16956-99
0000000	002083		157721-99	12/05/2022		4100-051500-1244-551-510	117.48	224097		Uniform Services	01856 # 16956-99
0000000	002083		157722-99	12/05/2022		4100-051100-1244-512-510	117.48	224097		Uniform Services	01856 # 16956-99
0000000	002083		157723-99	12/05/2022		4100-051100-1244-519-510	64.62	224097		Uniform Services	01856 # 16956-99
0000000	002083		157724-99	12/05/2022		4100-051100-1244-512-510	129.24	224097		Uniform Services	01856 # 16956-99
0000000	002083		157728-99	12/05/2022		4100-051500-1244-551-510	64.62	224097		Uniform Services	01856 # 16956-99
		.00 CHECK TOTAL		881.16	ACH PMT TOTAL	.00 CPA PMT TOTAL	.00	EPY PMT TOTAL			
0000000	002083	READ'S UNIFORMS INC.	157729-99	12/05/2022		4100-051100-1244-512-510	117.48	224098		Uniform Services	01856 # 16956-99
0000000	002083		157730-99	12/05/2022		4100-051500-1244-551-510	117.48	224098		Uniform Services	01856 # 16956-99
0000000	002083		157732-99	12/05/2022		4100-051100-1244-512-510	64.62	224098		Uniform Services	01856 # 16956-99
0000000	002083		157736-99	12/05/2022		4100-051100-1244-512-510	93.42	224098		Uniform Services	01856 # 16956-99
0000000	002083		157740-99	12/05/2022		4100-051500-1244-551-510	46.71	224098		Uniform Services	01856 # 16956-99
0000000	002083		157744-99	12/05/2022		4100-051100-1244-512-510	93.42	224098		Uniform Services	01856 # 16956-99
0000000	002083		157745-99	12/05/2022		4100-051500-1244-551-510	121.44	224098		Uniform Services	01856 # 16956-99
0000000	002083		157749-99	12/05/2022		4100-051100-1244-519-510	93.42	224098		Uniform Services	01856 # 16956-99
0000000	002083		157752-99	12/05/2022		4100-051100-1244-512-510	93.42	224098		Uniform Services	01856 # 16956-99
		.00 CHECK TOTAL		934.83	ACH PMT TOTAL	.00 CPA PMT TOTAL	.00	EPY PMT TOTAL			
0000000	002083	READ'S UNIFORMS INC.	157756-99	12/05/2022		4100-051100-1244-512-510	93.42	224099		Uniform Services	01856 # 16956-99
0000000	002083		157759-99	12/05/2022		4100-051100-1244-512-510	93.42	224099		Uniform Services	01856 # 16956-99
0000000	002083		157760-99	12/05/2022		4100-051500-1244-551-510	93.42	224099		Uniform Services	01856 # 16956-99
0000000	002083		157763-99	12/05/2022		4100-051500-1244-519-510	93.42	224099		Uniform Services	01856 # 16956-99
0000000	002083		157764-99	12/05/2022		4100-051100-1244-519-510	93.42	224099		Uniform Services	01856 # 16956-99
0000000	002083		157765-99	12/05/2022		4100-051500-1244-551-510	93.42	224099		Uniform Services	01856 # 16956-99
0000000	002083		157766-99	12/05/2022		4100-051100-1244-512-510	93.42	224099		Uniform Services	01856 # 16956-99
0000000	002083		157767-99	12/05/2022		4100-051500-1244-551-510	121.44	224099		Uniform Services	01856 # 16956-99
0000000	002083		157772-99	12/05/2022		4100-051100-1244-515-510	93.42	224099		Uniform Services	01856 # 16956-99
		.00 CHECK TOTAL		962.22	ACH PMT TOTAL	.00 CPA PMT TOTAL	.00	EPY PMT TOTAL			
0000000	002083	READ'S UNIFORMS INC.	157905-99	12/06/2022		4100-051100-1244-512-510	93.42	224100		Uniform Services	01856 # 16956-99
0000000	002083		157906-99	12/06/2022		4100-051500-1244-551-510	117.48	224100		Uniform Services	01856 # 16956-99
0000000	002083		157907-99	12/06/2022		4100-051100-1244-519-510	117.48	224100		Uniform Services	01856 # 16956-99
0000000	002083		157909-99	12/06/2022		4100-051500-1244-551-510	117.48	224100		Uniform Services	01856 # 16956-99
0000000	002083		157910-99	12/06/2022		4100-051500-1244-551-510	117.48	224100		Uniform Services	01856 # 16956-99
0000000	002083		157912-99	12/06/2022		4100-051100-1244-551-510	117.48	224100		Uniform Services	01856 # 16956-99
0000000	002083		157916-99	12/06/2022		4100-051500-1244-551-510	117.48	224100		Uniform Services	01856 # 16956-99
0000000	002083		157920-99	12/06/2022		4100-051100-1244-551-510	117.48	224100		Uniform Services	01856 # 16956-99
0000000	002083		157921-99	12/06/2022		4100-051500-1244-551-510	117.48	224100		Uniform Services	01856 # 16956-99
0000000	002083		159699-99	12/13/2022		4100-051100-1244-512-510	225.00	224100		Uniform Services	01856 # 16956-99
		.00 CHECK TOTAL		1,258.26	ACH PMT TOTAL	.00 CPA PMT TOTAL	.00	EPY PMT TOTAL			
0000000	002083	READ'S UNIFORMS INC.	646131-1	12/19/2022		4100-051100-1244-512-510	221.88	224101		Uniform Services	01856 # 16956-99
0000000	002083		646134-1	12/19/2022		4100-051100-1244-512-510	113.68	224101		Uniform Services	01856 # 16956-99
		.00 CHECK TOTAL		335.56	ACH PMT TOTAL	.00 CPA PMT TOTAL	.00	EPY PMT TOTAL			

P.O. NO.	VENDOR NO.	VENDOR NAME	INVOICE NO.	INVOICE DATE	A/P ACCLR	ACCOUNT NO.	NET AMOUNT	CHECK NO.	ACH PMT	G/L ACCOUNT DESC.	BATCH INV. DESCRIPTION
00000000	001488	RRS FOODSERVICE	2265187	1/04/2023		4100-051500-1246-551-510	2,206.17	224102	N	Food Supplies	01856 # 118626 2,206.17
		DISC. TOTAL								TOTAL	
00000000	000063	RUTHERFORD SUPPLY	1285228	12/22/2022		4100-021200-1247-221-210	956.78	224103		Janitorial Supplies	01856 # 118601 956.78
		DISC. TOTAL								TOTAL	
00000000	000832	SAM'S CLUB DIRECT	8419	12/13/2022		4100-051500-1246-551-510	18.46	224104		Food Supplies	01856 # 0402188473177
		DISC. TOTAL	8420	12/13/2022		4100-051500-1247-551-510	133.78	224104		Janitorial Supplies	01856 # 0402188473177 152.24
		DISC. TOTAL								TOTAL	
00000000	001787	SIMPLE.COM	19988-OTS	1/06/2023		4100-021600-1234-263-210	192.00	224105		Telecommunications	01856 SUSSEX COUNTY 192.00
		DISC. TOTAL								TOTAL	
00000000	001975	STAPLES, INC.	7370381516-0-1	12/13/2022		4100-021400-1241-241-210	101.44	224106		Office Supplies	01856 # 270656688 101.44
		DISC. TOTAL								TOTAL	
00000000	002022	STARZSTAR COMMUNICATIONS, L	SUB01486844	1/05/2023		4100-021600-1234-263-210	198.26	224107		Telecommunications	01856 # 812800 198.26
		DISC. TOTAL								TOTAL	
00000000	002086	STEMMLE PLUMBING REPAIR I	207599	11/30/2022		4100-021100-1229-211-210	3,476.00	224108		Other Professional Services	01856 SUSSEX COUNTY 3,476.00
		DISC. TOTAL								TOTAL	
00000000	000480	STONY CREEK VOLUNTEER	SCVFD 010923	1/09/2023		4100-021500-2110-251-210-502	10,000.00	224109		Stony Creek Vol Fire Dept	01856 REIMBURSEMENT 10,000.00
		DISC. TOTAL								TOTAL	
00000000	000162	SUFFOLK ENERGIES INC	37666049	12/09/2022		4100-021200-1278-221-210	763.68	224110		Oil	01856 # 66740484
		DISC. TOTAL	619165	10/31/2022		4100-021200-1278-221-210	68.19	224110		Oil	01856 # 66740484
		DISC. TOTAL	667654	12/21/2022		4100-021200-1278-221-210	621.20	224110		Oil	01856 # 66740484 1,453.07
		DISC. TOTAL								TOTAL	
00000000	000485	THOMSON WEST	847638859	1/01/2023		4100-063100-1202-631-630	317.00	224111		Pub... Subsc... Books, Ref. Mat	01856 # 1005559182 317.00
		DISC. TOTAL								TOTAL	
00000000	000080	TRI CITY OFFICE PRODUCTS	0143499-001-01	10/04/2022		4100-031100-1241-311-310	183.80	224112		Office Supplies	01856 # SCR-0
		DISC. TOTAL	0143912-001-01	12/08/2022		4100-041100-1241-411-410	119.40	224112		Office Supplies	01856 # STO-0 303.20
		DISC. TOTAL								TOTAL	
00000000	000418	V.A.L.E.C.O.	VALECO 010623	1/06/2023		4100-041100-1203-411-410	25.00	224113		Workshops and Conferences	01856 COX.DESTE 25.00
		DISC. TOTAL								TOTAL	
00000000	000087	VAN CLEEF AUTO PARTS INC	15976	12/01/2022		4100-021500-1265-251-210	481.09	224114		Vehicle Maintenance & Rpairs	01856 # 27430
		DISC. TOTAL	16101	12/14/2022		4100-021500-1265-253-210	1,041.28	224114		Vehicle Maintenance & Repairs	01856 # 27430
		DISC. TOTAL	16101	12/14/2022		4100-021500-1265-252-210	164.18	224114		Vehicle Maintenance & Repairs	01856 # 27430
		DISC. TOTAL								TOTAL	
00000000	000757	VERIZON BUSINESS	7509632	1/10/2023		4100-021600-1234-263-210	492.45	224115		Telecommunications	01856 # Y2694822 492.45
		DISC. TOTAL								TOTAL	
00000000	000039	VERIZON WIRELESS	9923356839	12/19/2022		4100-051500-1234-551-510	185.04	224116		Telecommunications	01856 # 742314083-00002
		DISC. TOTAL	9923356839	12/19/2022		4100-051100-1234-516-510	185.05	224116		Telecommunications	01856 # 742314083-00002
		DISC. TOTAL								TOTAL	

AP100 1/12/2023 SUSSEX COUNTY A/P CHECK REGISTER TIME-12:03:06 ActPd - 2023/01

P.O. NO.	VENDOR NO.	VENDOR NAME	INVOICE NO.	INVOICE DATE	A/P ACRL	ACCOUNT NO.	NET AMOUNT	CHECK NO.	ACH PMT TOTAL	G/L ACCOUNT DESC.	BATCH INV. DESCRIPTION
0000000	002050	VIRGINIA AMERICAN WATER C	976204	12/22/2022		4100-021200-1277-221-210	23.00	224117	.00	Water Services	01856 # 1027-21004597620
		DISC. TOTAL									23.00
0000000	001962	VIRGINIA S GATEWAY REGION	1585	12/31/2022		4100-021100-1229-211-210	2,500.00	224118	.00	Other Professional Services	01856 SUSSEX COUNTY
		DISC. TOTAL									2,500.00
0000000	000873	WASTE MANAGEMENT OF	3714189-2424-2	12/22/2022		4100-021600-1229-263-210	698.77	224119	.00	Other Professional Services	01856 # 103305252006
		DISC. TOTAL									698.77
0000000	000090	MAVERLY MOTORS, INC	17337	11/16/2022		4100-021700-1265-271-210	96.00	224120	.00	Vehicle Maintenance	01856 SUSSEX COUNTY
		DISC. TOTAL									96.00
0000000	002093	WEX BANK	85931369	12/23/2022		4100-021600-1278-264-210	451.00	224121	.00	Diesel Fuel	01856 # 0496-00-926622-2
		DISC. TOTAL									451.00
0000000	002093	WEX BANK	85931369	12/23/2022		4100-021200-1299-221-210	227.27	224121	.00	Miscellaneous Oth./First Aid	01856 # 0496-00-926622-2
		DISC. TOTAL									227.27
0000000	002093	WEX BANK	85931369	12/23/2022		4100-021600-1278-261-210	500.48	224121	.00	Miscellaneous Oth./First Aid	01856 # 0496-00-926622-2
		DISC. TOTAL									500.48
0000000	000879	WOMACK PUBLISHING CO.	48782	12/21/2022		4100-021100-1233-211-210	155.30	224122	.00	Printing	01856 # 5449
		DISC. TOTAL									155.30
0000000	001644	XEROX FINANCIAL SERVICES	3419922	8/10/2022		4100-051100-1252-512-510	340.44	224123	.00	Equipment Lease/Rental	01856 # 0200081249001
		DISC. TOTAL									340.44
0000000	001644	XEROX FINANCIAL SERVICES	3419922	8/10/2022		4100-051500-1252-551-510	340.43	224123	.00	Equipment Lease/Rental	01856 # 0200081249001
		DISC. TOTAL									340.43
0000000	000728	CARQUEST OF WAKEFIELD	15335-41457	12/29/2022		4100-021200-1265-221-210	62.39	224124	.00	Vehicle Maintenance & Repairs	01856 # 2836
		DISC. TOTAL									62.39
0000000	000049	JARRATT HARDWARE	2301-144328	1/09/2023		4100-023100-1241-291-230	5.97	224125	.00	Office Supplies	01856 # 1045
		DISC. TOTAL									5.97
0000000	000418	V.A.L.E.C.O.	VALECO 010622	1/06/2022		4100-041100-1203-411-410	30.00	224126	.00	Workshops and Conferences	01856 PARHAM RAVEN
		DISC. TOTAL									30.00
0000000	000090	MAVERLY MOTORS, INC	17378	12/12/2022		4100-051100-1255-512-510	20.00	224127	.00	Vehicle Maintenance & Repairs	01856 SUSSEX SHERIFF
		DISC. TOTAL									20.00
		DISC. TOTAL									103,879.75
		DISC. TOTAL									103,879.75

I HEREBY APPROVE THIS REGISTER FOR PAYMENT WITH EXCEPTIONS LISTED BELOW OR PREVIOUSLY DOCUMENTED. THE TOTAL 103,879.75- EQUALS THE WEEKLY LOG SHEET TOTALS AS ADJUSTED.

Richard Douglas
 DIRECTOR OF FINANCIAL SERVICES
 COUNTY ADMINISTRATION
 100 N. MARKET STREET
 DUNSMUIR, VA 22026

1-12-2023
 DATE

1/12/2023
 DATE

Richard Douglas
 COUNTY ADMINISTRATOR
 100 N. MARKET STREET
 DUNSMUIR, VA 22026

AP100 1/19/2023 SUSSEX COUNTY			A/P CHECK REGISTER			TIME - 9:18:24 ActPd - 2023/01		PAGE 1				
P.O. NO.	VENDOR NO.	VENDOR NAME	INVOICE NO.	INVOICE DATE	A/P ACCRL	ACCOUNT NO.	NET AMOUNT	CHECK NO.	ACH PMT	ACH PMT	G/L ACCOUNT DESC.	BATCH INV. DESCRIPTION
0000000	001917	AMAZON CAPTIAL SERVICES	1896-JFKY-16K4	12/13/2022		4100-021600-1247-261-210	74.01	224129			Janitorial Supplies	01857 # A1WJ83SE5CTAJC
0000000	001917		1WNF-QKP6-4w9M	1/04/2023		4100-021200-1247-221-210	890.43	224129			Janitorial Supplies	01857 # A1WJ83SE5CTAJC
0000000	001917		14P3-K6QL-34Y9	12/13/2022		4100-021600-1242-261-210	181.16	224129			Agricultural Supplies	01857 # A1WJ83SE5CTAJC
		DISC TOTAL					.00				EPY PMT TOTAL	1.145.60
		CHECK TOTAL									TOTAL	
0000000	001769	ATLANTIC EMERGENCY SOLUTI	32246EQU	1/17/2023		4100-021500-1259-251-210	5,600.00	224130			Other Equipment Purchases	01857 # 17366
		DISC TOTAL					.00				EPY PMT TOTAL	5,600.00
		CHECK TOTAL									TOTAL	
0000000	001507	BARKSDALE OILS INC.	SUSSCTY 123122	12/31/2022		4100-021400-1264-241-210	92.44	224131			Mileage	01857 # SUSSCTY
0000000	001507		SUSSCTY 123122	12/31/2022		4100-021600-1264-261-210	1,484.12	224131			Mileage	01857 # SUSSCTY
0000000	001507		SUSSCTY 123122	12/31/2022		4100-021200-1264-221-210	1,576.56	224131			Mileage	01857 # SUSSCTY
0000000	001507		SUSSCTY 123122	12/31/2022		4100-021600-1264-262-210	916.96	224131			Mileage	01857 # SUSSCTY
0000000	001507		SUSSCTY 123122	12/31/2022		4100-021400-1264-241-210	327.31	224131			Mileage	01857 # SUSSCTY
0000000	001507		SUSSCTY 123122	12/31/2022		4100-051100-1264-512-510	129.92	224131			Mileage/Gas	01857 # SUSSCTY
0000000	001507		SUSSCTY 123122	12/31/2022		4100-051100-1264-512-510	17,129.84	224131			Mileage/Gas	01857 # SUSSCTY
0000000	001507		SUSSCTY 123122	12/31/2022		4105-071100-1264-711-710	577.16	224131			Gasoline	01857 # SUSSCTY
		DISC TOTAL					.00				EPY PMT TOTAL	22,234.31
		CHECK TOTAL									TOTAL	
0000000	000300	BATTERY BARN OF VA INC	415796	1/17/2023		4100-021500-1254-252-210	316.00	224132			Equipment Maintenance	01857 # 749
		DISC TOTAL					.00				EPY PMT TOTAL	316.00
		CHECK TOTAL									TOTAL	
0000000	999999	BIVENS.DEVIN	DB 1222	1/09/2023		4100-051500-1215-551-510	96.30	224133			Inmate Pay	01857 INMATE PAY
		DISC TOTAL					.00				EPY PMT TOTAL	96.30
		CHECK TOTAL									TOTAL	
0000000	000915	BLACKWATER REGIONAL	151	1/01/2023		4100-081400-2110-826-810	47,565.00	224134			Blackwater/Regional Library	01857 SUSSEX COUNTY
		DISC TOTAL					.00				EPY PMT TOTAL	47,565.00
		CHECK TOTAL									TOTAL	
0000000	000181	BUCKLEY'S SECURITYSMITHS	99437	1/04/2022		4100-021200-1272-221-210	253.50	224135			Building Maintenance & Repair	01857 SUSSEX COUNTY
		DISC TOTAL					.00				EPY PMT TOTAL	253.50
		CHECK TOTAL									TOTAL	
0000000	001620	C.W.WARTHEN INC.	55518	1/09/2023		4100-062100-1241-621-620	1,293.92	224136			Office Supplies	01857 SUSSEX COUNTY
		DISC TOTAL					.00				EPY PMT TOTAL	1,293.92
		CHECK TOTAL									TOTAL	
0000000	001251	CABIN POINT VETERINARY	74881	12/09/2022		4100-021600-1227-261-210	87.00	224137			Medical Services	01857 # 1707
0000000	001251		74895	12/12/2022		4100-021600-1227-261-210	87.00	224137			Medical Services	01857 # 1707
0000000	001251		74918	12/13/2022		4100-021600-1227-261-210	1,657.00	224137			Medical Services	01857 # 1707
0000000	001251		74947	12/14/2022		4100-021600-1227-261-210	274.50	224137			Medical Services	01857 # 1707
0000000	001251		74978	12/20/2022		4100-021600-1227-261-210	928.00	224137			Medical Services	01857 # 1707
0000000	001251		75037	12/21/2022		4100-021600-1227-261-210	302.00	224137			Medical Services	01857 # 1707
0000000	001251		75095	12/27/2022		4100-021600-1227-261-210	509.00	224137			Medical Services	01857 # 1707
		DISC TOTAL					.00				EPY PMT TOTAL	3,844.50
		CHECK TOTAL									TOTAL	
0000000	002101	CAMPBELL PET COMPANY	0403745-IN	12/07/2022		4100-021600-1242-261-210	530.04	224138			Agricultural Supplies	01857 # 23882
		DISC TOTAL					.00				EPY PMT TOTAL	530.04
		CHECK TOTAL									TOTAL	
0000000	000728	CARQUEST OF WAKEFIELD	15335-41697	1/07/2023		4100-051100-1265-512-510	74.20	224139			Vehicle Maintenance & Repairs	01857 # 5001
0000000	000728		15335-41813	1/12/2023		4100-051100-1265-512-510	171.90	224139			Vehicle Maintenance & Repairs	01857 # 5001
		DISC TOTAL					.00				EPY PMT TOTAL	246.10
		CHECK TOTAL									TOTAL	
0000000	000021	CARTER MACHINERY CO. INC	1272782	12/28/2022		4100-021200-1273-221-210	513.81	224140			Building Systems Main & Repai	01857 # 25625
		DISC TOTAL					.00				EPY PMT TOTAL	513.81
		CHECK TOTAL									TOTAL	

API00 1/19/2023 SUSSEX COUNTY A/P CHECK REGISTER TIME- 9:18:24 ActPd - 2023/01 PAGE 2

P.O. NO.	VENDOR NO.	VENDOR NAME	INVOICE NO.	INVOICE DATE	A/P ACRL	ACCOUNT NO.	NET AMOUNT	CHECK NO.	ACH PMT	ACH PMT	G/L	ACCOUNT DESC.	BATCH	INV. DESCRIPTION
0000000	001485	CENTRAL AGRIBUSINESS	JR31351	12/16/2022		4100-051500-1246-551-510	61.60	224141				Food Supplies	01857	SUSSEX SHERIFF
0000000	001485		JR31653	1/11/2023		4100-051500-1246-551-510	46.20	224141				Food Supplies	01857	SUSSEX SHERIFF
		DISC. TOTAL					.00	EPY PMT TOTAL				TOTAL		107.80
0000000	001630	CHENEY BROTHERS	12-923989307	1/11/2023		4100-051500-1246-551-510	1,885.83	224142				Food Supplies	01857	# 60030700
		DISC. TOTAL					.00	EPY PMT TOTAL				TOTAL		1,885.83
0000000	002063	CITY OF RICHMOND	DECEMBER2022-01	12/31/2022		4100-021100-1299-211-210	1,100.00	224143				Miscellaneous Others	01857	SUSSEX SHERIFF
		DISC. TOTAL					.00	EPY PMT TOTAL				TOTAL		1,100.00
0000000	002055	COMMONWEALTH CALIBRATIONS 2023-#81		1/11/2023		4100-051100-1265-519-510	75.00	224144				Vehicle Maintenance Repairs	01857	SUSSEX SHERIFF
		DISC. TOTAL					.00	EPY PMT TOTAL				TOTAL		75.00
0000000	000871	CRYSTAL SPRINGS	10726073	12/24/2022		4100-021200-1277-221-210	15.00	224145				Water Services	01857	# 508239010726073
		DISC. TOTAL					.00	EPY PMT TOTAL				TOTAL		15.00
0000000	000902	DOC FARMER'S MARKET	MKT97281	1/09/2023		4100-051500-1246-551-510	274.70	224146				Food Supplies	01857	SUSSEX COUNTY JAIL
		DISC. TOTAL					.00	EPY PMT TOTAL				TOTAL		274.70
0000000	001651	DOCUMENT SYSTEMS	122724	5/03/2022		4100-021600-1252-261-210	83.30	224147				Equipment Lease/Rental	01857	# SC11
0000000	001651		123312	6/01/2022		4100-021600-1252-261-210	76.26	224147				Equipment Lease/Rental	01857	# SC11
0000000	001651		124619	8/02/2022		4100-021600-1252-261-210	67.56	224147				Equipment Lease/Rental	01857	# SC11
0000000	001651		125313	9/02/2022		4100-021600-1252-261-210	61.70	224147				Equipment Lease/Rental	01857	# SC11
0000000	001651		127863	1/04/2023		4100-021600-1252-261-210	67.43	224147				Equipment Lease/Rental	01857	# SC11
		DISC. TOTAL					.00	EPY PMT TOTAL				TOTAL		356.25
0000000	000084	DOMINION VIRGINIA POWER	0561293952	12/29/2022		4100-021600-1276-263-210	6.59	224148				Electric	01857	# 0561293952
0000000	000084		1088433121	12/30/2022		4100-021600-1276-263-210	154.20	224148				Electric	01857	# 1088433121
0000000	000084		2406362505	12/30/2022		4100-051500-1276-551-510	2,181.97	224148				Electric	01857	# 2406362505
0000000	000084		2921584914	12/30/2022		4100-051500-1276-551-510	6.59	224148				Electric	01857	# 2921584914
0000000	000084		3500335009	12/30/2022		4100-021600-1276-263-210	2,230.79	224148				Electric	01857	# 3500335009
0000000	000084		3776508966	01/23/2023		4100-021600-1276-263-210	6.59	224148				Electric	01857	# 3776508966
0000000	000084		4204030300	12/29/2022		4100-021600-1276-263-210	69.89	224148				Electric	01857	# 4204030300
0000000	000084		4714897313	12/30/2022		4100-021600-1276-263-210	79.36	224148				Electric	01857	# 4714897313
0000000	000084		5690307508	12/29/2022		4100-021500-1279-251-210	341.06	224148				Propane Gas & Electric	01857	# 5690307508
0000000	000084		6305358712	12/29/2022		4100-021600-1276-264-210	133.31	224148				Electric	01857	# 6305358712
		DISC. TOTAL					.00	EPY PMT TOTAL				TOTAL		5,210.35
0000000	000084	DOMINION VIRGINIA POWER	6860160149	12/30/2022		4100-021600-1276-263-210	1,184.33	224149				Electric	01857	# 6860160149
0000000	000084		7190905005	12/30/2022		4100-021600-1276-263-210	232.65	224149				Electric	01857	# 7190905005
0000000	000084		7378703693	12/29/2022		4100-021600-1276-264-210	116.29	224149				Electric	01857	# 7378703693
0000000	000084		7860242267	12/30/2022		4100-021600-1276-263-210	441.24	224149				Electric	01857	# 7860242267
0000000	000084		8855852839	12/29/2022		4100-021600-1276-263-210	362.19	224149				Electric	01857	# 8855852839
0000000	000084		9073933633	12/29/2022		4100-051500-1276-551-510	49.90	224149				Electric	01857	# 9073933633
0000000	000084		9560347503	12/30/2022		4100-021600-1276-263-210	2,017.51	224149				Electric	01857	# 9560347503
0000000	000084		9630317502	12/30/2022		4100-021600-1276-263-210	1,291.13	224149				Electric	01857	# 9630317502
0000000	000084		9650330005	12/30/2022		4100-021600-1276-263-210	1,030.49	224149				Electric	01857	# 9650330005
0000000	000084		9660330003	12/29/2022		4100-021600-1276-263-210	134.10	224149				Electric	01857	# 9660330003
		DISC. TOTAL					.00	EPY PMT TOTAL				TOTAL		6,859.83
0000000	000084	DOMINION VIRGINIA POWER	9670342501	12/30/2022		4100-021600-1276-263-210	96.55	224150				Electric	01857	# 9670342501
		DISC. TOTAL					.00	EPY PMT TOTAL				TOTAL		96.55

AP100 1/19/2023 SUSSEX COUNTY			A/P CHECK REGISTER			TIME- 9:18:24 ActPd - 2023/01		PAGE 3				
P.O. NO.	VENDOR NO.	VENDOR NAME	INVOICE NO.	INVOICE DATE	A/P ACCRL	ACCOUNT NO.	NET AMOUNT	CHECK NO.	ACH PMT	ACH G/L	ACCOUNT DESC.	BATCH INV DESCRIPTION
0000000	001692	FERRELLGAS	1121247409	11/29/2022		4100-021200-1279-221-210	2,842.99	224151			Propane Gas	01857 # 112364120
0000000	001692		1121619473	12/22/2022		4100-021200-1279-221-210	2,812.38	224151			Propane Gas	01857 # 112364120
		DISC TOTAL					.00	EPY PMT TOTAL			TOTAL	5,655.37
0000000	000602	FIRE-X CORPORATION	621840	12/31/2022		4100-062100-1254-621-620	616.40	224152			Equipment Maintenance	01857 # SU0025
		DISC TOTAL					.00	EPY PMT TOTAL			TOTAL	616.40
0000000	002103	JETHRO BYRD ELECTRICAL &	6754	12/28/2022		4100-051500-1272-551-510	1,215.00	224153			Building Maintenance & Repair	01857 SUSSEX SHERIFF
		DISC TOTAL					.00	EPY PMT TOTAL			TOTAL	1,215.00
0000000	001115	LIFESTAR AMBULANCE	SCI22022	1/17/2023		4100-021500-2110-252-210-524	23,040.00	224154			Emergency Med SVC - Pd EMT	01857 DECEMBER 2022
0000000	001115		WAV122022	1/17/2023		4100-021500-2110-252-210-524	53,568.00	224154			Emergency Med. SVC - Pd EMT	01857 DECEMBER 2022
0000000	001115		WT122022	1/17/2023		4100-021500-2110-252-210-524	27,900.00	224154			Emergency Med. SVC - Pd EMT	01857 SUSSEX PUBLIC SAFE
		DISC TOTAL					.00	EPY PMT TOTAL			TOTAL	104,508.00
0000000	001433	LOWE'S	911334-01	12/29/2022		4100-051500-1272-551-510	47.65	224155			Building Maintenance & Repair	01857 # 99003370360
		DISC TOTAL					.00	EPY PMT TOTAL			TOTAL	47.65
0000000	001983	MID-ATLANTIC PEST AND LAW MAPL	011023	1/10/2023		4100-021200-1274-221-210	315.00	224156			Grounds Maintenance & Repairs	01857 SUSSEX COUNTY
0000000	001983		MAPL 121322	12/13/2022		4100-021600-1274-261-210	190.00	224156			Grounds Maintenance & Repairs	01857 SUSSEX ANML CONTRO
		DISC TOTAL					.00	EPY PMT TOTAL			TOTAL	505.00
0000000	999999	NEWMAN, MICHAEL	MN 1222	1/09/2023		4100-051500-1215-551-510	116.55	224157			Inmate Pay	01857 INMATE PAY
		DISC TOTAL					.00	EPY PMT TOTAL			TOTAL	116.55
0000000	000056	OWEN FORD, INC	21142	1/09/2023		4100-021600-1265-262-210	117.52	224158			Vehicle Maintenance & Repairs	01857 SUSSEX COUNTY
		DISC TOTAL					.00	EPY PMT TOTAL			TOTAL	117.52
0000000	002102	RAY MALLORY	2022-00486	12/28/2022		4100-051100-1227-512-510	245.00	224159			Medical Services inc/t9	01857 SUSSEX SHERIFF
		DISC TOTAL					.00	EPY PMT TOTAL			TOTAL	245.00
0000000	999999	RICHARDSON, CORNELL	CR 1222	1/09/2023		4100-051500-1215-551-510	18.90	224160			Inmate Pay	01857 INMATE PAY
		DISC TOTAL					.00	EPY PMT TOTAL			TOTAL	18.90
0000000	002104	RICHARDSON, JEFFREY	JR 010623	1/17/2023		4100-051100-1244-512-510	75.00	224161			Uniform Services	01857 REIMBURSEMENT
		DISC TOTAL					.00	EPY PMT TOTAL			TOTAL	75.00
0000000	000063	RUTHERFORD SUPPLY	1285975	1/05/2023		4100-021200-1247-221-210	281.76	224162			Janitorial Supplies	01857 # 118601
0000000	000063		1286497	1/06/2023		4100-021200-1247-221-210	238.00	224162			Janitorial Supplies	01857 # 118601
		DISC TOTAL					.00	EPY PMT TOTAL			TOTAL	519.76
0000000	999999	SMITH, TORIANDO	TS 1222	1/09/2023		4100-051500-1246-551-510	72.00	224163			Food Supplies	01857 INMATE PAY
		DISC TOTAL					.00	EPY PMT TOTAL			TOTAL	72.00
0000000	001772	SOUTHSIDE ELECTRIC COOPER	561962001 0123	1/05/2023		4100-021600-1276-264-210	124.91	224164			Electric	01857 # 561962001
		DISC TOTAL					.00	EPY PMT TOTAL			TOTAL	124.91
0000000	000067	STONY CREEK PHARMACY	SCP 011723	1/17/2023		4100-051500-1293-551-510	800.45	224165			Inmate Medical Expenses	01857 DECEMBER 2022
		DISC TOTAL					.00	EPY PMT TOTAL			TOTAL	800.45
0000000	000162	SUFFOLK ENERGIES INC	37668914	1/04/2023		4100-021200-1278-221-210	794.77	224166			Oil	01857 # 66740484

AP100 1/19/2023 SUSSEX COUNTY			A/P CHECK REGISTER			TIME- 9:18:24 ActPd - 2023/01							PAGE 4
P.O. NO.	VENDOR NO.	VENDOR NAME	INVOICE NO.	INVOICE DATE	A/P ACCRL	ACCOUNT NO.	NET AMOUNT	CHECK NO.	ACH PMT	ACH G/L	ACCOUNT DESC.	BATCH INV.	DESCRIPTION
0000000	000162		623927	12/31/2022		4100-051100-1264-512-510	159.32	224166			Mileage/Gas	01857 # 66740352	
	DISC. TOTAL	.00	CHECK TOTAL	954.09	ACH PMT TOTAL	.00	CPA PMT TOTAL				TOTAL	954.09	
0000000	001869	SUSSEX DISTRICT COURT	SCD 011723	1/17/2023		4100-061100-1223-611-610	2,198.59	224167			Legal Services - Court Appt.	01857 REIMBURSEMENT	
	DISC. TOTAL	.00	CHECK TOTAL	2,198.59	ACH PMT TOTAL	.00	CPA PMT TOTAL				TOTAL	2,198.59	
0000000	000077	SUSSEX SERVICE AUTHORITY	165 1022	10/31/2022		4100-021600-1277-263-210	6,404.40	224168			Water Services	01857 # 41638	
0000000	000077		166 1122	11/30/2022		4100-021600-1277-263-210	6,229.40	224168			Water Services	01857 # 41638	
0000000	000077		167 1222	12/31/2022		4100-021600-1277-263-210	4,872.80	224168			Water Services	01857 # 41638	
	DISC. TOTAL	.00	CHECK TOTAL	17,506.60	ACH PMT TOTAL	.00	CPA PMT TOTAL				TOTAL	17,506.60	
0000000	000081	THACKER HARDWARE	79041/1	12/19/2022		4100-021200-1272-221-210	116.45	224169			Building Maintenance & Repair	01857 # 341500	
	DISC. TOTAL	.00	CHECK TOTAL	116.45	ACH PMT TOTAL	.00	CPA PMT TOTAL				TOTAL	116.45	
0000000	000316	TOWN OF STONY CREEK	TWN SC 0123	1/12/2023		4100-041100-1296-411-410	1,054.20	224170			Refund to Towns	01857 VEH.LIC.REG.SHARE	
	DISC. TOTAL	.00	CHECK TOTAL	1,054.20	ACH PMT TOTAL	.00	CPA PMT TOTAL				TOTAL	1,054.20	
0000000	000317	TOWN OF WAKEFIELD	TWN WKFLD 0123	1/12/2023		4100-041100-1296-411-410	3,848.41	224171			Refund to Towns	01857 VEH.LIC.REG.SHARE	
	DISC. TOTAL	.00	CHECK TOTAL	3,848.41	ACH PMT TOTAL	.00	CPA PMT TOTAL				TOTAL	3,848.41	
0000000	000318	TOWN OF WAVERLY	TWN WAV 0123	1/12/2023		4100-041100-1296-411-410	7,787.73	224172			Refund to Towns	01857 VEH.LIC.REG.SHARE	
	DISC. TOTAL	.00	CHECK TOTAL	7,787.73	ACH PMT TOTAL	.00	CPA PMT TOTAL				TOTAL	7,787.73	
0000000	001833	TRANSUNION RISK & ALTERNA	5687311-202212	1/01/2023		4100-051100-1229-512-510	75.00	224173			Other Professional Services	01857 # 5687311	
	DISC. TOTAL	.00	CHECK TOTAL	75.00	ACH PMT TOTAL	.00	CPA PMT TOTAL				TOTAL	75.00	
0000000	000080	TRI CITY OFFICE PRODUCTS	0143479-001	10/20/2022		4100-062100-1241-621-620	590.48	224174			Office Supplies	01857 # SXCC-0	
0000000	000080		0144163-001	1/10/2023		4100-031100-1241-311-310	129.34	224174			Office Supplies	01857 # SCR-0	
	DISC. TOTAL	.00	CHECK TOTAL	719.82	ACH PMT TOTAL	.00	CPA PMT TOTAL				TOTAL	719.82	
0000000	000087	VAN CLEEF AUTO PARTS INC	641465	12/15/2022		4100-021600-1242-261-210	33.00	224175			Agricultural Supplies	01857 # 27430	
0000000	000087		641653	12/21/2022		4100-021600-1242-261-210	123.96	224175			Agricultural Supplies	01857 # 27430	
0000000	000087		642185	1/03/2023		4100-021600-1265-261-210	18.86	224175			Vehicle Maintenance & Repairs	01857 # 27430	
0000000	000087		642380	1/06/2023		4100-021600-1242-261-210	154.95	224175			Agricultural Supplies	01857 # 27430	
	DISC. TOTAL	.00	CHECK TOTAL	330.77	ACH PMT TOTAL	.00	CPA PMT TOTAL				TOTAL	330.77	
0000000	000039	VERIZON WIRELESS	9925076960	1/10/2023		4100-011100-1234-111-110	94.79	224176			Telecommunications	01857 # 805250394-00001	
0000000	000039		9925076960	1/10/2023		4100-021100-1234-211-210	330.95	224176			Telecommunications	01857 # 805250394-00001	
0000000	000039		9925076960	1/10/2023		4100-021200-1234-221-210	201.73	224176			Telecommunications	01857 # 805250394-00001	
0000000	000039		9925076960	1/10/2023		4100-021500-1234-253-210	88.46	224176			Telecommunications	01857 # 805250394-00001	
0000000	000039		9925076960	1/10/2023		4100-021600-1234-261-210	314.52	224176			Telecommunications	01857 # 805250394-00001	
0000000	000039		9925076960	1/10/2023		4100-021600-1234-262-210	88.46	224176			Mobile Telecommunications	01857 # 805250394-00001	
0000000	000039		9925076960	1/10/2023		4100-021600-1234-263-210	40.01	224176			Telecommunications	01857 # 805250394-00001	
0000000	000039		9925076960	1/10/2023		4100-023100-1234-291-230	40.01	224176			Telecommunications	01857 # 805250394-00001	
0000000	000039		9925076960	1/10/2023		4100-031100-1234-311-310	40.01	224176			Telecommunications	01857 # 805250394-00001	
0000000	000039		9925076960	1/10/2023		4100-041100-1234-411-410	40.01	224176			Telecommunications	01857 # 805250394-00001	
	DISC. TOTAL	.00	CHECK TOTAL	1,278.95	ACH PMT TOTAL	.00	CPA PMT TOTAL				TOTAL	1,278.95	
0000000	000879	WOMACK PUBLISHING CO.	47940	11/23/2022		4100-021100-1235-211-210	244.80	224177			Advertising	01857 # 5504	
	DISC. TOTAL	.00	CHECK TOTAL	244.80	ACH PMT TOTAL	.00	CPA PMT TOTAL				TOTAL	244.80	

AP100 1/19/2023 SUSSEX COUNTY			A/P CHECK REGISTER			TIME- 9:18:24	ActPd - 2023/01	PAGE 5				
P.O. NO.	VENDOR NO.	VENDOR NAME	INVOICE NO.	INVOICE DATE	A/P ACCRL	ACCOUNT NO.	NET AMOUNT	CHECK NO.	ACH PMT	ACH G/L	ACCOUNT DESC.	BATCH INV DESCRIPTION
0000000	001966	WOOTEN COMPANY, THE	77925	1/13/2023		4100-021100-1228-211-210-601	2,225.00	224178			Wildcat Swamp Ditch Maint	Pr01857 PRJ# 3399-D
	DISC TOTAL	.00	CHECK TOTAL	2,225.00	ACH PMT TOTAL	.00	CPA PMT TOTAL	.00	EPY PMT TOTAL		TOTAL	2,225.00
0000000	001644	XEROX FINANCIAL SERVICES	2538423	3/15/2021		4100-021600-1252-261-210	118.00	224179			Equipment Lease/Rental	01857 # 0200074478001
0000000	001644		2629911	5/15/2021		4100-021600-1252-261-210	118.00	224179			Equipment Lease/Rental	01857 # 0200074478001
0000000	001644		3376275	7/15/2022		4100-021600-1252-261-210	118.00	224179			Equipment Lease/Rental	01857 # 0200074478001
0000000	001644		3494891	9/14/2022		4100-021600-1252-261-210	118.00	224179			Equipment Lease/Rental	01857 # 0200074478001
0000000	001644		3556567	10/15/2022		4100-021600-1252-261-210	118.00	224179			Equipment Lease/Rental	01857 # 0200074478001
0000000	001644		3610566	11/14/2022		4100-021600-1252-261-210	118.00	224179			Equipment Lease/Rental	01857 # 0200074478001
0000000	001644		3680417	12/15/2022		4100-021600-1252-261-210	118.00	224179			Equipment Lease/Rental	01857 # 0200074478001
0000000	001644		3744561	1/15/2023		4100-021600-1252-261-210	118.00	224179			Equipment Lease/Rental	01857 # 0200074478001
	DISC TOTAL	.00	CHECK TOTAL	944.00	ACH PMT TOTAL	.00	CPA PMT TOTAL	.00	EPY PMT TOTAL		TOTAL	944.00
0000000	000871	CRYSTAL SPRINGS	12841556	011623	1/16/2023	4100-063100-1277-631-630	34.97	224180			Water Services	01857 # 114253012841556
	DISC TOTAL	.00	CHECK TOTAL	34.97	ACH PMT TOTAL	.00	CPA PMT TOTAL	.00	EPY PMT TOTAL		TOTAL	34.97
0000000	000879	WOMACK PUBLISHING CO.	48744		12/28/2022	4100-023100-1235-291-230	136.00	224181			Advertising	01857 # 5439
	DISC TOTAL	.00	CHECK TOTAL	136.00	ACH PMT TOTAL	.00	CPA PMT TOTAL	.00	EPY PMT TOTAL		TOTAL	136.00
0000000	001644	XEROX FINANCIAL SERVICES	3726881	1/10/2023		4100-051100-1252-512-510	299.93	224182			Equipment Lease/Rental	01857 # 0200081249001
0000000	001644		3726881	1/10/2023		4100-051500-1252-551-510	299.93	224182			Equipment Lease/Rental	01857 # 0200081249001
	DISC TOTAL	.00	CHECK TOTAL	599.86	ACH PMT TOTAL	.00	CPA PMT TOTAL	.00	EPY PMT TOTAL		TOTAL	599.86
				254,313.14	ACH PMT TOTAL	.00	CPA PMT TOTAL	.00	EPY PMT TOTAL		TOTAL	254,313.14
				254,313.14	ACH PMT TOTAL	.00	CPA PMT TOTAL	.00	EPY PMT TOTAL		TOTAL	254,313.14

I HEREBY APPROVE THIS REGISTER FOR PAYMENT WITH EXCEPTIONS LISTED BELOW OR PREVIOUSLY DOCUMENTED THE TOTAL 254,313.14- EQUALS THE WEEKLY LOG SHEET TOTALS AS ADJUSTED.

DATE
1-19-23
1/19/2023
DATE
1/19/23
DATE

Richard Douglas
DIRECTOR OF FINANCE
Kelly Bellis
COUNTY COMPTROLLER

P.O. NO.	VENDOR NO.	VENDOR NAME	INVOICE NO.	INVOICE DATE	A/P ACRL	ACCOUNT NO.	NET AMOUNT	CHECK NO.	ACH PMT	G/L ACCOUNT DESC.	BATCH INV. DESCRIPTION
0000000	9999999	ALEXANDER BLIZZARD	000002041221011JU	10/11/2022	60.00	4100-061100-1213-611-610	60.00	224183	60.00	Witness Fees	01859 JUROR PAYMNT
			CHECK TOTAL				.00	EPY PMT TOTAL			60.00
0000000	9999999	ARLENE ALDRIDGE-BRANCH	000000724221011JU	10/11/2022	60.00	4100-061100-1213-611-610	60.00	224184	60.00	Witness Fees	01859 JUROR PAYMNT
			CHECK TOTAL				.00	EPY PMT TOTAL			60.00
0000000	9999999	BARBARA SMITH GRAY	000001443221011JU	10/11/2022	60.00	4100-061100-1213-611-610	60.00	224185	60.00	Witness Fees	01859 JUROR PAYMNT
			CHECK TOTAL				.00	EPY PMT TOTAL			60.00
0000000	9999999	BRIAN KIRK HARVELL	000000449221011JU	10/11/2022	30.00	4100-061100-1213-611-610	30.00	224186	30.00	Witness Fees	01859 JUROR PAYMNT
			CHECK TOTAL				.00	EPY PMT TOTAL			30.00
0000000	9999999	CHARLOTTE YVONNE JONES	000000295221011JU	10/11/2022	30.00	4100-061100-1213-611-610	30.00	224187	30.00	Witness Fees	01859 JUROR PAYMNT
			CHECK TOTAL				.00	EPY PMT TOTAL			30.00
0000000	9999999	CURTIS M. BAINES	000002039221011JU	10/11/2022	60.00	4100-061100-1213-611-610	60.00	224188	60.00	Witness Fees	01859 JUROR PAYMNT
			CHECK TOTAL				.00	EPY PMT TOTAL			60.00
0000000	9999999	DAVID BUJOK-MUDGE	000002040221011JU	10/11/2022	60.00	4100-061100-1213-611-610	60.00	224189	60.00	Witness Fees	01859 JUROR PAYMNT
			CHECK TOTAL				.00	EPY PMT TOTAL			60.00
0000000	9999999	DEBORAH BOWDEN BARTLEY	000002030221011JU	10/11/2022	30.00	4100-061100-1213-611-610	30.00	224190	30.00	Witness Fees	01859 JUROR PAYMNT
			CHECK TOTAL				.00	EPY PMT TOTAL			30.00
0000000	9999999	DEMITRES C. GARRETT	000002035221011JU	10/11/2022	60.00	4100-061100-1213-611-610	60.00	224191	60.00	Witness Fees	01859 JUROR PAYMNT
			CHECK TOTAL				.00	EPY PMT TOTAL			60.00
0000000	9999999	DOUGLAS CARROL DUNN	000001781221011JU	10/11/2022	60.00	4100-061100-1213-611-610	60.00	224192	60.00	Witness Fees	01859 JUROR PAYMNT
			CHECK TOTAL				.00	EPY PMT TOTAL			60.00
0000000	9999999	DOUGLAS L. LAWRENCE, III	000002044221011JU	10/11/2022	60.00	4100-061100-1213-611-610	60.00	224193	60.00	Witness Fees	01859 JUROR PAYMNT
			CHECK TOTAL				.00	EPY PMT TOTAL			60.00
0000000	9999999	ERICKA D. STITH	000002057221011JU	10/11/2022	30.00	4100-061100-1213-611-610	30.00	224194	30.00	Witness Fees	01859 JUROR PAYMNT
			CHECK TOTAL				.00	EPY PMT TOTAL			30.00
0000000	9999999	ERIN C. DODSON	000002052221011JU	10/11/2022	60.00	4100-061100-1213-611-610	60.00	224195	60.00	Witness Fees	01859 JUROR PAYMNT
			CHECK TOTAL				.00	EPY PMT TOTAL			60.00
0000000	9999999	FLOYD ALONZO GOODE	000000764221011JU	10/11/2022	60.00	4100-061100-1213-611-610	60.00	224196	60.00	Witness Fees	01859 JUROR PAYMNT
			CHECK TOTAL				.00	EPY PMT TOTAL			60.00
0000000	9999999	FREDDIE A. STRINGFIELD	000000081221011JU	10/11/2022	30.00	4100-061100-1213-611-610	30.00	224197	30.00	Witness Fees	01859 JUROR PAYMNT
			CHECK TOTAL				.00	EPY PMT TOTAL			30.00
0000000	9999999	FREDERICK HERBERT STITH	000001086221011JU	10/11/2022	30.00	4100-061100-1213-611-610	30.00	224198	30.00	Witness Fees	01859 JUROR PAYMNT
			CHECK TOTAL				.00	EPY PMT TOTAL			30.00
0000000	9999999	GARY FREEMAN GILLES	000001305221011JU	10/11/2022	60.00	4100-061100-1213-611-610	60.00	224199	60.00	Witness Fees	01859 JUROR PAYMNT
			CHECK TOTAL				.00	EPY PMT TOTAL			60.00

P.O. NO.	VENDOR NO.	VENDOR NAME	INVOICE NO.	INVOICE DATE	A/P ACRL	ACCOUNT NO.	NET AMOUNT	CHECK NO.	ACH PMT	ACH PMT TOTAL	G/L ACCOUNT DESC.	BATCH INV. DESCRIPTION
0000000	9999999	HAZEL B. FLOWERS	000002034221011JU	10/11/2022	30.00	4100-061100-1213-611-610	30.00	224200	30.00	30.00	Witness Fees	01859 JUROR PAYMNT
			CHECK TOTAL			.00 CPA PMT TOTAL	.00	EPY PMT TOTAL			.00	30.00
0000000	9999999	JAMES BRANCH	000002042221011JU	10/11/2022	30.00	4100-061100-1213-611-610	30.00	224201	30.00	30.00	Witness Fees	01859 JUROR PAYMNT
			CHECK TOTAL			.00 CPA PMT TOTAL	.00	EPY PMT TOTAL			.00	30.00
0000000	9999999	JAMES EDMONDS	000002058221011JU	10/11/2022	60.00	4100-061100-1213-611-610	60.00	224202	60.00	60.00	Witness Fees	01859 JUROR PAYMNT
			CHECK TOTAL			.00 CPA PMT TOTAL	.00	EPY PMT TOTAL			.00	60.00
0000000	9999999	JASON D. JESSUP	00000504221011JU	10/11/2022	60.00	4100-061100-1213-611-610	60.00	224203	60.00	60.00	Witness Fees	01859 JUROR PAYMNT
			CHECK TOTAL			.00 CPA PMT TOTAL	.00	EPY PMT TOTAL			.00	60.00
0000000	9999999	JOHN CYPRESS	000002051221011JU	10/11/2022	30.00	4100-061100-1213-611-610	30.00	224204	30.00	30.00	Witness Fees	01859 JUROR PAYMNT
			CHECK TOTAL			.00 CPA PMT TOTAL	.00	EPY PMT TOTAL			.00	30.00
0000000	9999999	JOHN D. WORREL	000002048221011JU	10/11/2022	60.00	4100-061100-1213-611-610	60.00	224205	60.00	60.00	Witness Fees	01859 JUROR PAYMNT
			CHECK TOTAL			.00 CPA PMT TOTAL	.00	EPY PMT TOTAL			.00	60.00
0000000	9999999	JOHN R. NORRIS, JR.	000002038221011JU	10/11/2022	60.00	4100-061100-1213-611-610	60.00	224206	60.00	60.00	Witness Fees	01859 JUROR PAYMNT
			CHECK TOTAL			.00 CPA PMT TOTAL	.00	EPY PMT TOTAL			.00	60.00
0000000	9999999	JOYCE WILLIAMS	000002060221011JU	10/11/2022	30.00	4100-061100-1213-611-610	30.00	224207	30.00	30.00	Witness Fees	01859 JUROR PAYMNT
			CHECK TOTAL			.00 CPA PMT TOTAL	.00	EPY PMT TOTAL			.00	30.00
0000000	9999999	JUDITH BOBBITT HARRELL	000001345221011JU	10/11/2022	60.00	4100-061100-1213-611-610	60.00	224208	60.00	60.00	Witness Fees	01859 JUROR PAYMNT
			CHECK TOTAL			.00 CPA PMT TOTAL	.00	EPY PMT TOTAL			.00	60.00
0000000	9999999	JUSTIN HARRELL ELLIS	000000157221011JU	10/11/2022	30.00	4100-061100-1213-611-610	30.00	224209	30.00	30.00	Witness Fees	01859 JUROR PAYMNT
			CHECK TOTAL			.00 CPA PMT TOTAL	.00	EPY PMT TOTAL			.00	30.00
0000000	9999999	KIMBERLY MITCHELL WALTON	0000000857221011JU	10/11/2022	60.00	4100-061100-1213-611-610	60.00	224210	60.00	60.00	Witness Fees	01859 JUROR PAYMNT
			CHECK TOTAL			.00 CPA PMT TOTAL	.00	EPY PMT TOTAL			.00	60.00
0000000	9999999	KRISTIE UPTON	000002056221011JU	10/11/2022	30.00	4100-061100-1213-611-610	30.00	224211	30.00	30.00	Witness Fees	01859 JUROR PAYMNT
			CHECK TOTAL			.00 CPA PMT TOTAL	.00	EPY PMT TOTAL			.00	30.00
0000000	9999999	LORETTA JAMES	000002053221011JU	10/11/2022	30.00	4100-061100-1213-611-610	30.00	224212	30.00	30.00	Witness Fees	01859 JUROR PAYMNT
			CHECK TOTAL			.00 CPA PMT TOTAL	.00	EPY PMT TOTAL			.00	30.00
0000000	9999999	MARIE ANN MITCHELL	000001420221011JU	10/11/2022	30.00	4100-061100-1213-611-610	30.00	224213	30.00	30.00	Witness Fees	01859 JUROR PAYMNT
			CHECK TOTAL			.00 CPA PMT TOTAL	.00	EPY PMT TOTAL			.00	30.00
0000000	9999999	MARY MAGUIRE	000002054221011JU	10/11/2022	30.00	4100-061100-1213-611-610	30.00	224214	30.00	30.00	Witness Fees	01859 JUROR PAYMNT
			CHECK TOTAL			.00 CPA PMT TOTAL	.00	EPY PMT TOTAL			.00	30.00
0000000	9999999	MELVIN C. TRISVAN	000001853221011JU	10/11/2022	60.00	4100-061100-1213-611-610	60.00	224215	60.00	60.00	Witness Fees	01859 JUROR PAYMNT
			CHECK TOTAL			.00 CPA PMT TOTAL	.00	EPY PMT TOTAL			.00	60.00
0000000	9999999	MELVIN L. LILES, JR.	000002050221011JU	10/11/2022	60.00	4100-061100-1213-611-610	60.00	224216	60.00	60.00	Witness Fees	01859 JUROR PAYMNT
			CHECK TOTAL			.00 CPA PMT TOTAL	.00	EPY PMT TOTAL			.00	60.00

AP100 1/24/2023 SUSSEX COUNTY A/P CHECK REGISTER TIME-10:44:48 ActPd - 2023/01

P.O. NO.	VENDOR NO.	VENDOR NAME	INVOICE NO.	INVOICE DATE	A/P ACCL	ACCOUNT NO.	NET AMOUNT	CHECK NO.	ACH PMT	G/L ACCOUNT DESC.	BATCH INV. DESCRIPTION
0000000	9999999	MICHELLE CHERRY MAYES	000001575221011JU	10/11/2022		4100-061100-1213-611-610	60.00	224217	TOTAL	Witness Fees .00	01859 JUROR PAYMNT 60.00
		DISC. TOTAL	CHECK TOTAL	60.00	ACH PMT TOTAL	.00 CPA PMT TOTAL					
0000000	9999999	PERRY L. BRADSHAW	000001604221011JU	10/11/2022		4100-061100-1213-611-610	60.00	224218	TOTAL	Witness Fees .00	01859 JUROR PAYMNT 60.00
		DISC. TOTAL	CHECK TOTAL	60.00	ACH PMT TOTAL	.00 CPA PMT TOTAL					
0000000	9999999	PHILLIP BAGWELL	000002045221011JU	10/11/2022		4100-061100-1213-611-610	60.00	224219	TOTAL	Witness Fees .00	01859 JUROR PAYMNT 60.00
		DISC. TOTAL	CHECK TOTAL	60.00	ACH PMT TOTAL	.00 CPA PMT TOTAL					
0000000	9999999	RAKEEM L. WHITE	000002047221011JU	10/11/2022		4100-061100-1213-611-610	60.00	224220	TOTAL	Witness Fees .00	01859 JUROR PAYMNT 60.00
		DISC. TOTAL	CHECK TOTAL	60.00	ACH PMT TOTAL	.00 CPA PMT TOTAL					
0000000	9999999	ROBIN A. JOHNSON	000002046221011JU	10/11/2022		4100-061100-1213-611-610	60.00	224221	TOTAL	Witness Fees .00	01859 JUROR PAYMNT 60.00
		DISC. TOTAL	CHECK TOTAL	60.00	ACH PMT TOTAL	.00 CPA PMT TOTAL					
0000000	9999999	ROBIN TAYLOR	000002055221011JU	10/11/2022		4100-061100-1213-611-610	30.00	224222	TOTAL	Witness Fees .00	01859 JUROR PAYMNT 30.00
		DISC. TOTAL	CHECK TOTAL	30.00	ACH PMT TOTAL	.00 CPA PMT TOTAL					
0000000	9999999	RUBY WAGES SADLER	000002036221011JU	10/11/2022		4100-061100-1213-611-610	30.00	224223	TOTAL	Witness Fees .00	01859 JUROR PAYMNT 30.00
		DISC. TOTAL	CHECK TOTAL	30.00	ACH PMT TOTAL	.00 CPA PMT TOTAL					
0000000	9999999	SAMUEL D. MOORE	000002037221011JU	10/11/2022		4100-061100-1213-611-610	60.00	224224	TOTAL	Witness Fees .00	01859 JUROR PAYMNT 60.00
		DISC. TOTAL	CHECK TOTAL	60.00	ACH PMT TOTAL	.00 CPA PMT TOTAL					
0000000	9999999	SHUNTA BARNES-JOHNSON	000002043221011JU	10/11/2022		4100-061100-1213-611-610	60.00	224225	TOTAL	Witness Fees .00	01859 JUROR PAYMNT 60.00
		DISC. TOTAL	CHECK TOTAL	60.00	ACH PMT TOTAL	.00 CPA PMT TOTAL					
0000000	9999999	TELESE COLEY	000002049221011JU	10/11/2022		4100-061100-1213-611-610	30.00	224226	TOTAL	Witness Fees .00	01859 JUROR PAYMNT 30.00
		DISC. TOTAL	CHECK TOTAL	30.00	ACH PMT TOTAL	.00 CPA PMT TOTAL					
0000000	9999999	THOMAS DEWEY COOKE JR.	000002032221011JU	10/11/2022		4100-061100-1213-611-610	30.00	224227	TOTAL	Witness Fees .00	01859 JUROR PAYMNT 30.00
		DISC. TOTAL	CHECK TOTAL	30.00	ACH PMT TOTAL	.00 CPA PMT TOTAL					
0000000	9999999	TINA VALENTINE	000002059221011JU	10/11/2022		4100-061100-1213-611-610	30.00	224228	TOTAL	Witness Fees .00	01859 JUROR PAYMNT 30.00
		DISC. TOTAL	CHECK TOTAL	30.00	ACH PMT TOTAL	.00 CPA PMT TOTAL					
0000000	9999999	VALARIE PATTERSON-RICKS	000002031221011JU	10/11/2022		4100-061100-1213-611-610	30.00	224229	TOTAL	Witness Fees .00	01859 JUROR PAYMNT 30.00
		DISC. TOTAL	CHECK TOTAL	30.00	ACH PMT TOTAL	.00 CPA PMT TOTAL					
0000000	9999999	VERONICA A. PEGRAM	000002033221011JU	10/11/2022		4100-061100-1213-611-610	60.00	224230	TOTAL	Witness Fees .00	01859 JUROR PAYMNT 60.00
		DISC. TOTAL	CHECK TOTAL	60.00	ACH PMT TOTAL	.00 CPA PMT TOTAL					
0000000	9999999	VICTORIA A. LORD	000002012221011JU	10/11/2022		4100-061100-1213-611-610	30.00	224231	TOTAL	Witness Fees .00	01859 JUROR PAYMNT 30.00
		DISC. TOTAL	CHECK TOTAL	30.00	ACH PMT TOTAL	.00 CPA PMT TOTAL					
0000000	9999999	WALTER ENMETT WESTBROOK	000001064221011JU	10/11/2022		4100-061100-1213-611-610	30.00	224232	TOTAL	Witness Fees .00	01859 JUROR PAYMNT 30.00
		DISC. TOTAL	CHECK TOTAL	30.00	ACH PMT TOTAL	.00 CPA PMT TOTAL					
			CHECK TOTAL	2,310.00	ACH PMT TOTAL	.00 CPA PMT TOTAL					2,310.00
			CHECK TOTAL	2,310.00	ACH PMT TOTAL	.00 CPA PMT TOTAL					2,310.00

I HEREBY APPROVE THIS REGISTER FOR PAYMENT WITH EXCEPTIONS LISTED BELOW OR PREVIOUSLY DOCUMENTED.
 THE TOTAL 2,310.00- EQUALS THE WEEKLY LOG SHEET TOTALS AS ADJUSTED.

1-24-23 Key sign
 1-24-23 Richard Dwyer
 1/26/23 West of Cox

P.O. NO.	VENDOR NO.	VENDOR NAME	INVOICE NO.	INVOICE DATE	A/P ACCR	ACCOUNT NO.	NET AMOUNT	CHECK NO.	ACH PMT	G/L ACCOUNT DESC.	BATCH INV. DESCRIPTION
0000000	001960	ACI PAYMENTS, INC.	1000085493	1/17/2023		4100-041100-1292-411-410	4,159.93	224245	.00	Bank/CC & Other Fees	01858 # 39343 4,159.93
			CHECK TOTAL							TOTAL	
0000000	001917	AMAZON CAPTIAL SERVICES	1010-VX06-94T1	1/20/2023		4100-021500-1254-253-210	550.29	224246	.00	Equipment Maintenance	01858 # AIUJ83SE5CTAJC 550.29
			CHECK TOTAL							TOTAL	
0000000	001011	ANTHEM BLUE CROSS& SHIELD	53273727715	1/18/2023		4100-051500-1293-551-510	726.80	224247	.00	Inmate Medical Expenses	01858 # 5327370866 726.80
			CHECK TOTAL							TOTAL	
0000000	002024	ATLAS GEOGRAPHIC DATA, INC	A22-054-2	1/18/2023		4100-021400-1228-241-210	4,650.00	224248	.00	Contractual Services	01858 SUSSEX COUNTY 4,650.00
			CHECK TOTAL							TOTAL	
0000000	000010	BANK OF SOUTHSIDE VA	0255 0123 01	12/11/2022		4100-051100-1245-512-510	44.07	224249	.00	Law Enforcement Supplies	01858 SHERIFF ACCT
			0255 0123 02	12/14/2022		4100-051100-1256-512-510	44.64	224249	.00	Communication Equipment	01858 SHERIFF ACCT
			0255 0123 03	12/15/2022		4100-051100-1241-516-510	13.50	224249	.00	Office Supplies	01858 SHERIFF ACCT
			0255 0123 04	12/17/2022		4100-051100-1241-512-510	15.94	224249	.00	Office Supplies	01858 SHERIFF ACCT
			0255 0123 05	12/21/2022		4100-051100-1245-512-510	942.44	224249	.00	Law Enforcement Supplies	01858 SHERIFF ACCT
			0255 0123 06	12/23/2022		4100-051500-1293-551-510	10.39	224249	.00	Inmate Medical Expenses	01858 SHERIFF ACCT
			0255 0123 07	12/23/2022		4100-051500-1293-551-510	12.99	224249	.00	Inmate Medical Expenses	01858 SHERIFF ACCT
			0255 0123 08	12/23/2022		4100-051100-1241-512-510	26.57	224249	.00	Office Supplies	01858 SHERIFF ACCT
			0255 0123 09	12/23/2022		4100-051100-1241-512-510	25.38	224249	.00	Office Supplies	01858 SHERIFF ACCT
			0255 0123 10	12/23/2022		4100-051100-1241-512-510	7.99	224249	.00	Office Supplies	01858 SHERIFF ACCT
			CHECK TOTAL				1,143.91			TOTAL	1,143.91
0000000	000010	BANK OF SOUTHSIDE VA	0255 0123 11	12/28/2022		4100-051500-1293-551-510	10.79	224250	.00	Inmate Medical Expenses	01858 SHERIFF ACCT
			0255 0123 12	12/29/2022		4100-051100-1245-512-510	15.01	224250	.00	Law Enforcement Supplies	01858 SHERIFF ACCT
			0255 0123 13	1/04/2023		4100-051100-1245-512-510	36.98	224250	.00	Law Enforcement Supplies	01858 SHERIFF ACCT
			CHECK TOTAL				62.78			TOTAL	62.78
0000000	001676	BERKLEY GROUP	WO#9A INV#13	1/17/2023		4100-021400-1225-241-210	3,333.33	224251	.00	Management Consulting Service	01858 PLANNER POSITION
			WO#9B INV#13	1/17/2023		4100-021400-1225-241-210	3,920.00	224251	.00	Management Consulting Service	01858 PLANNING DIRECTOR
			CHECK TOTAL				7,253.33			TOTAL	7,253.33
0000000	002105	BLUE BIRO MEADOW	#SUSSEX 23-02	1/17/2023		4100-021500-1254-251-210	390.00	224252	.00	Equipment Maintenance	01858 SUSSEX PUBLIC SAFE 390.00
			CHECK TOTAL				390.00			TOTAL	390.00
0000000	000738	BUTLER'S TOWING AND	12392	1/19/2023		4100-051100-1265-515-510	36.00	224253	.00	Vehicle Maintenance & Repairs	01858 SUSSEX SHERIFF
			12399	1/20/2023		4100-051100-1265-512-510	24.00	224253	.00	Vehicle Maintenance & Repairs	01858 SUSSEX SHERIFF
			12407	1/20/2023		4100-051100-1265-512-510	25.94	224253	.00	Vehicle Maintenance & Repairs	01858 SUSSEX SHERIFF
			CHECK TOTAL				85.94			TOTAL	85.94
0000000	000728	CARQUEST OF WAKEFIELD	15335-42030	1/20/2023		4100-051100-1265-519-510	114.18	224254	.00	Vehicle Maintenance Repairs	01858 # 5001
			5484-176721	1/20/2023		4100-051100-1265-512-510	21.14	224254	.00	Vehicle Maintenance & Repairs	01858 # 5001
			CHECK TOTAL				135.32			TOTAL	135.32
0000000	001485	CENTRAL AGRIBUSINESS	JR31731	1/18/2023		4100-051500-1246-551-510	61.60	224255	.00	Food Supplies	01858 SUSSEX SHERIFF 61.60
			CHECK TOTAL				61.60			TOTAL	61.60
0000000	002106	CIVICPLUS	244425	12/01/2022		4100-021100-1229-211-210	550.00	224256	.00	Other Professional Services	01858 SUSSEX COUNTY 550.00
			CHECK TOTAL				550.00			TOTAL	550.00

P.O. NO.	VENDOR NO.	VENDOR NAME	INVOICE NO.	INVOICE DATE	A/P ACCRL	ACCOUNT NO.	NET AMOUNT	CHECK NO.	ACH PMT	ACH PMT TOTAL	G/L ACCOUNT DESC.	BATCH INV. DESCRIPTION
0000000	000622	COUNTY OF GREENSVILLE	3042	1/01/2023		4100-061100-1214-611-610	3,129.82	224257		3,129.82	Comp Court Administrator	01858 ACCT# 65
		.00 CHECK TOTAL				.00 CPA PMT TOTAL					.00	3,129.82
0000000	000845	CROWN CASTLE GT COMPANY	40260072	2/01/2023		4100-021500-1252-253-210	1,382.35	224258		1,382.35	Equipment Lease/Rental	01858 # 106663
		.00 CHECK TOTAL				.00 CPA PMT TOTAL					.00	1,382.35
0000000	001931	DAVENPORT & COMPANY LLC	PF22-234	11/15/2022		4100-021100-1228-211-210	37,560.05	224259		37,560.05	Contractual Services	01858 SUSSEX COUNTY
		.00 CHECK TOTAL				.00 CPA PMT TOTAL					.00	37,560.05
0000000	000902	DOC FARMER'S MARKET	MKT97439	1/17/2023		4100-051500-1246-551-510	249.85	224260		249.85	Food Supplies	01858 SUSSEX COUNTY JAIL
		.00 CHECK TOTAL				.00 CPA PMT TOTAL					.00	249.85
0000000	000902	DOC FARMER'S MARKET	MKT97597	1/23/2023		4100-051500-1246-551-510	280.92	224260		280.92	Food Supplies	01858 SUSSEX COUNTY JAIL
		.00 CHECK TOTAL				.00 CPA PMT TOTAL					.00	530.77
0000000	001651	DOCUMENT SYSTEMS	128024	1/09/2023		4100-021100-1252-211-210	99.00	224261		99.00	Equipment Lease/Rental	01858 # SC05-004
		.00 CHECK TOTAL				.00 CPA PMT TOTAL					.00	99.00
0000000	001692	FERRELLGAS	1121956107	1/19/2023		4100-051500-1279-551-510	728.42	224262		728.42	Propane Gas	01858 # 112364120
		.00 CHECK TOTAL				.00 CPA PMT TOTAL					.00	728.42
0000000	001087	FIRE PROTECTION	FS1162#1	12/30/2022		4100-051500-1273-551-510	403.45	224263		403.45	Building Systems Main & Repai	01858 SUSSEX SHERIFF
		.00 CHECK TOTAL				.00 CPA PMT TOTAL					.00	403.45
0000000	001605	GLOBAL SIGNAL ACQUISITIONS	40320365	2/01/2023		4100-021500-1252-253-210	477.62	224264		477.62	Equipment Lease/Rental	01858 # 393860
		.00 CHECK TOTAL				.00 CPA PMT TOTAL					.00	477.62
0000000	001951	HGS LLC	IN26654	6/01/2022		4100-021100-1228-211-210	105.00	224265		105.00	Contractual Services	01858 PROJ# PRJ103735
		.00 CHECK TOTAL				.00 CPA PMT TOTAL					.00	105.00
0000000	001550	KINEX NETWORKING SOLUTION	2301-0013615	1/19/2023		4100-021600-1234-263-210	1,350.00	224266		1,350.00	Telecommunications	01858 # SUB-2201-00000487
		.00 CHECK TOTAL				.00 CPA PMT TOTAL					.00	1,350.00
0000000	000390	KUSTOM SIGNALS, INC	596983	9/14/2022		4100-051100-1245-512-510	6,192.00	224267		6,192.00	Law Enforcement Supplies	01858 # 12075
		.00 CHECK TOTAL				.00 CPA PMT TOTAL					.00	6,192.00
0000000	000829	PURCHASE POWER	10888506	10/13/2022		4100-063100-1231-632-630	100.00	224268		100.00	Postage	01858 # 8000909010888506
		.00 CHECK TOTAL				.00 CPA PMT TOTAL					.00	100.00
0000000	001023	RICOH USA, INC.	37512362	1/13/2023		4100-063100-1252-631-630	232.33	224269		232.33	Equipment Lease/Rental	01858 # 37023603
		.00 CHECK TOTAL				.00 CPA PMT TOTAL					.00	232.33
0000000	001869	SUSSEX DISTRICT COURT	SCD 012023	1/20/2023		4100-061100-1223-611-610	480.00	224270		480.00	Legal Services - Court Appt.	01858 RETIMBURSEMENT
		.00 CHECK TOTAL				.00 CPA PMT TOTAL					.00	480.00
0000000	001766	THE SUPPLY ROOM	4856815-0	1/19/2023		4100-051100-1241-516-510	10.20	224271		10.20	Office Supplies	01858 SUSSEX SHERIFF
		.00 CHECK TOTAL				.00 CPA PMT TOTAL					.00	10.20
0000000	001766	THE SUPPLY ROOM	4856815-0	1/19/2023		4100-051100-1241-516-510	5.98	224271		5.98	Office Supplies	01858 SUSSEX SHERIFF
		.00 CHECK TOTAL				.00 CPA PMT TOTAL					.00	5.98
0000000	001869	SUSSEX DISTRICT COURT	SCD 012523	1/25/2023		4100-061100-1223-611-610	24.00	224271		24.00	Office Supplies	01858 SUSSEX SHERIFF
		.00 CHECK TOTAL				.00 CPA PMT TOTAL					.00	24.00
0000000	001833	TRANSUNION RISK & ALTERNA	5687311-202208	9/01/2021		4100-051100-1229-512-510	75.00	224272		75.00	Other Professional Services	01858 # 5687311
		.00 CHECK TOTAL				.00 CPA PMT TOTAL					.00	75.00

P.O. NO.	VENDOR NO.	VENDOR NAME	INVOICE NO.	INVOICE DATE	A/P ACRL	ACCOUNT NO.	NET AMOUNT	CHECK NO.	ACH PMT	BATCH INV. DESCRIPTION
0000000	000080	TRI CITY OFFICE PRODUCTS	0143145-001	8/18/2022		4100-031100-1241-311-310	26.55	224273		Office Supplies
0000000	000080		0144242-001	1/17/2023		4100-031100-1241-311-310	275.00	224273		Office Supplies
		DISC. TOTAL					.00	EPY PMT TOTAL		TOTAL
0000000	001995	TRUIST BANK	2338 0123 01	12/20/2022		4100-021100-1203-211-210	375.00	224274		Workshops and Conferences
0000000	001995		2338 0123 02	12/22/2022		4100-011100-1203-111-110	150.00	224274		Workshops and Conferences
0000000	001995		2338 0123 03	12/22/2022		4100-021100-1203-211-210	300.00	224274		Workshops and Conferences
0000000	001995		2338 0123 04	12/27/2022		4100-021100-1258-211-210	29.98	224274		Computer Software/Applications
0000000	001995		2338 0123 05	1/06/2023		4100-041100-1203-411-410	80.00	224274		Workshops and Conferences
0000000	001995		2338 0123 06	1/06/2023		4100-041100-1203-411-410	80.00	224274		Workshops and Conferences
0000000	001995		2338 0123 07	1/06/2023		4100-041100-1203-411-410	160.00	224274		Workshops and Conferences
0000000	001995		2338 0123 08	1/11/2023		4100-021100-1258-211-210	239.88	224274		Computer Software/Applications
0000000	001995		2338 0123 09	1/17/2023		4100-021500-1264-253-210	48.36	224274		Mileage
		DISC. TOTAL					.00	EPY PMT TOTAL		TOTAL
0000000	000039	VERIZON WIRELESS	9925196915	1/12/2023		4100-051500-1234-551-510	146.91	224275		Telecommunications
0000000	000039		9925196915	1/12/2023		4100-051100-1234-512-510	500.07	224275		Telecommunications
0000000	000039		9925196915	1/12/2023		4100-051100-1234-516-510	500.07	224275		Telecommunications
		DISC. TOTAL					.00	EPY PMT TOTAL		TOTAL
0000000	001209	VIRGINIA COOPERATIVE EXT BILL SALRY	23/2	1/13/2022		4100-081300-2110-822-810	6,176.39	224276		VA Cooperative Extension
		DISC. TOTAL					.00	EPY PMT TOTAL		TOTAL
0000000	000581	VIRGINIA DINER	121222	12/12/2022		4100-021100-1205-211-210	235.20	224277		Meals
		DISC. TOTAL					.00	EPY PMT TOTAL		TOTAL
0000000	999999	VVAN	3093	12/18/2022		4100-063100-1201-632-630	50.00	224278		Organization Memberships
		DISC. TOTAL					.00	EPY PMT TOTAL		TOTAL
0000000	001078	WILKINS & COMPANY, INC	122822	12/28/2022		4123-085000-5210-	450.00	224279		Construction - Budget Project
		DISC. TOTAL					.00	EPY PMT TOTAL		TOTAL
0000000	001644	XEROX FINANCIAL SERVICES	3693676	12/25/2022		4100-031100-1252-311-310	145.00	224280		Equipment Lease/Rental
		DISC. TOTAL					.00	EPY PMT TOTAL		TOTAL
0000000	000010	BANK OF SOUTHSIDE VA	0107 0123 01	12/23/2022		4100-051500-1246-551-510	28.64	224281		Food Supplies
0000000	000010		0107 0123 02	12/30/2022		4100-051500-1246-551-510	20.00	224281		Food Supplies
		DISC. TOTAL					.00	EPY PMT TOTAL		TOTAL
0000000	002105	BLUE BIRD MEADOW	#SUSSEX-23-01	1/11/2023		4100-051500-1272-551-510	910.00	224282		Building Maintenance & Repair
		DISC. TOTAL					.00	EPY PMT TOTAL		TOTAL
0000000	001995	TRUIST BANK	2346 0123 01	1/19/2022		4100-021100-1203-211-210	1,005.00	224283		Workshops and Conferences
		DISC. TOTAL					.00	EPY PMT TOTAL		TOTAL
0000000	000039	VERIZON WIRELESS	9922720039	12/10/2022		4100-063100-1234-631-630	187.48	224284		Telecommunications
0000000	000039		9922720039	12/10/2022		4100-063100-1234-632-630	49.11	224284		Telecommunications
0000000	000039		9925100533	1/10/2023		4100-063100-1234-631-630	187.56	224284		Telecommunications
0000000	000039		9925100533	1/10/2023		4100-063100-1234-632-630	49.14	224284		Telecommunications
		DISC. TOTAL					.00	EPY PMT TOTAL		TOTAL
		DISC. TOTAL					.00	EPY PMT TOTAL		TOTAL
		DISC. TOTAL					.00	EPY PMT TOTAL		TOTAL
		DISC. TOTAL					.00	EPY PMT TOTAL		TOTAL

I HEREBY APPROVE THIS REGISTER FOR PAYMENT WITH EXCEPTIONS LISTED BELOW OR PREVIOUSLY DOCUMENTED.

1-26-23 *Karyn...*

1-26-23 *Rachel...*

1/26/23 *West...*

PAYROLL DEDUCTION CHECKS



P/O NO.	VEND. NO.	VENDOR NAME	INVOICE NO.	INVOICE DATE	ACCOUNT NO.	CHECK NO.	NET AMOUNT	DESCRIPTION	BATCH
00000	000245	AFLAC	DC040230116230100	1/13/2023	100-000200-0100-	224040	752.29		00000
00000	000245		DC040230116230100	1/13/2023	105-000200-0100-	224040	87.17		00000
00000	000245		DC041230116230100	1/13/2023	100-000200-0100-	224040	562.81		00000
00000	000245		DC041230116230100	1/13/2023	105-000200-0100-	224040	133.91		00000
					CHECK TOTAL		1,536.18		
00000	000881	ANTHEM BLUE CROSS AND	DC005230116230100	1/13/2023	100-000200-0100-	224041	9,022.50		00000
00000	000881		DC005230116230100	1/13/2023	105-000200-0100-	224041	1,203.00		00000
00000	000881		DC015230116230100	1/13/2023	100-000200-0100-	224041	5,265.00		00000
00000	000881		DC126230116230100	1/13/2023	100-000200-0100-	224041	25,675.00		00000
00000	000881		DC126230116230100	1/13/2023	105-000200-0100-	224041	4,875.00		00000
					CHECK TOTAL		46,040.50		
00000	002034	CHAPPELL REAL ESTATE, INC	DC133230116230100	1/13/2023	100-000200-0100-	224042	374.68		00000
					CHECK TOTAL		374.68		
00000	001625	CITY OF PETERSBURG	DC112230116230100	1/13/2023	100-000200-0100-	224043	443.05		00000
					CHECK TOTAL		443.05		
00000	002099	IRON BRIDGE HOLDING COMPA	DC135230116230100	1/13/2023	100-000200-0100-	224044	214.92		00000
					CHECK TOTAL		214.92		
00000	001180	KAREN A. TAYLOR, TREASURER	DC068230116230100	1/13/2023	105-000200-0100-	224045	268.56		00000
					CHECK TOTAL		268.56		
00000	001397	LEGAL SHIELD	DC097230116230100	1/13/2023	100-000200-0100-	224046	44.88		00000
00000	001397		DC097230116230100	1/13/2023	105-000200-0100-	224046	14.95		00000
					CHECK TOTAL		59.83		
00000	001021	MINNESOTA LIFE INS CO	DC200230116230100	1/13/2023	100-000200-0100-	224047	483.30		00000
00000	001021		DC200230116230100	1/13/2023	105-000200-0100-	224047	104.71		00000
					CHECK TOTAL		588.01		
00000	000872	NATIONWIDE RETIREMENT	DC090230116230100	1/13/2023	100-000200-0100-	224048	345.00		00000
00000	000872		DC090230116230100	1/13/2023	105-000200-0100-	224048	25.00		00000
					CHECK TOTAL		370.00		
00000	001570	NEW JERSEY FAMILY	DC108230116230100	1/13/2023	100-000200-0100-	224049	179.84		00000
					CHECK TOTAL		179.84		
00000	001851	NYS CHILD SUPPORT PROCESS	DC114230116230100	1/13/2023	100-000200-0100-	224050	121.33		00000
					CHECK TOTAL		121.33		
00000	002087	TRANSWORLD SYSTEMS, INC.	DC134230116230100	1/13/2023	100-000200-0100-	224051	222.90		00000
					CHECK TOTAL		222.90		
00000	000247	TREASURER OF VIRGINIA	DC080230116230100	1/13/2023	100-000200-0100-	224052	2,119.92		00000
					CHECK TOTAL		2,119.92		
00000	000831	VACORP	DC035230116230100	1/13/2023	100-000200-0100-	224053	274.17		00000
00000	000831		DC035230116230100	1/13/2023	105-000200-0100-	224053	84.73		00000
					CHECK TOTAL		358.90		

P/O NO.	VENDOR NAME	INVOICE NO.	INVOICE DATE	ACCOUNT NO.	CHECK NO.	NET AMOUNT	DESCRIPTION	BATCH
00000	001027 VALIC RETIREMENT	DC091230116230100	1/13/2023	100-000200-0100-	224054	625.00		00000
						625.00		
						53,523.62	CLASS TOTAL	
						53,523.62-	FINAL TOTAL	

I HEREBY APPROVE THIS REGISTER FOR PAYMENT WITH EXCEPTIONS LISTED BELOW OR PREVIOUSLY DOCUMENTED.
 THE TOTAL 53,523.62- EQUALS THE WEEKLY LOG SHEET TOTALS AS ADJUSTED.

1-10-23
DATE

Richard L. Taylor
COUNTY ADMINISTRATOR

11/10/23

Kelly Bellis

P/O NO.	VEND. NO.	VENDOR NAME	INVOICE NO.	INVOICE DATE	ACCOUNT NO.	NET AMOUNT	CHECK NO.	DESCRIPTION	BATCH
00000	000245	AFLAC	DC040230131230100	1/31/2023	100-000200-0100-	752.29	224233		00000
00000	000245		DC040230131230100	1/31/2023	105-000200-0100-	87.17	224233		00000
00000	000245		DC041230131230100	1/31/2023	100-000200-0100-	562.81	224233		00000
00000	000245		DC041230131230100	1/31/2023	105-000200-0100-	133.91	224233		00000
					CHECK TOTAL	1,536.18			
00000	000881	ANTHEM BLUE CROSS AND	DC005230131230100	1/31/2023	100-000200-0100-	9,022.50	224234		00000
00000	000881		DC005230131230100	1/31/2023	105-000200-0100-	1,203.00	224234		00000
00000	000881		DC015230131230100	1/31/2023	100-000200-0100-	5,265.00	224234		00000
00000	000881		DC126230131230100	1/31/2023	100-000200-0100-	25,025.00	224234		00000
00000	000881		DC126230131230100	1/31/2023	105-000200-0100-	4,225.00	224234		00000
					CHECK TOTAL	44,740.50			
00000	002034	CHAPPELL REAL ESTATE, INC	DC133230131230100	1/31/2023	100-000200-0100-	292.24	224235		00000
					CHECK TOTAL	292.24			
00000	001180	KAREN A. TAYLOR, TREASURER	DC068230131230100	1/31/2023	105-000200-0100-	268.56	224236		00000
					CHECK TOTAL	268.56			
00000	001397	LEGAL SHIELD	DC097230131230100	1/31/2023	100-000200-0100-	44.88	224237		00000
00000	001397		DC097230131230100	1/31/2023	105-000200-0100-	14.95	224237		00000
					CHECK TOTAL	59.83			
00000	001021	MINNESOTA LIFE INS CO	DC200230131230100	1/31/2023	100-000200-0100-	516.20	224238		00000
00000	001021		DC200230131230100	1/31/2023	105-000200-0100-	122.17	224238		00000
					CHECK TOTAL	638.37			
00000	000872	NATIONWIDE RETIREMENT	DC090230131230100	1/31/2023	100-000200-0100-	345.00	224239		00000
00000	000872		DC090230131230100	1/31/2023	105-000200-0100-	25.00	224239		00000
					CHECK TOTAL	370.00			
00000	001851	NYS CHILD SUPPORT PROCESS	DC114230131230100	1/31/2023	100-000200-0100-	121.33	224240		00000
					CHECK TOTAL	121.33			
00000	002087	TRANSWORLD SYSTEMS, INC.	DC134230131230100	1/31/2023	100-000200-0100-	222.90	224241		00000
					CHECK TOTAL	222.90			
00000	000247	TREASURER OF VIRGINIA	DC080230131230100	1/31/2023	100-000200-0100-	2,099.24	224242		00000
					CHECK TOTAL	2,099.24			
00000	000831	VACORP	DC035230131230100	1/31/2023	100-000200-0100-	299.93	224243		00000
00000	000831		DC035230131230100	1/31/2023	105-000200-0100-	110.69	224243		00000
					CHECK TOTAL	410.62			
00000	001027	VALIC RETIREMENT	DC091230131230100	1/31/2023	100-000200-0100-	625.00	224244		00000
					CHECK TOTAL	625.00			
					CLASS TOTAL	51,384.77			
					FINAL TOTAL	51,384.77			

I HEREBY APPROVE THIS REGISTER FOR PAYMENT WITH EXCEPTIONS LISTED BELOW OR PREVIOUSLY DOCUMENTED.
 THE TOTAL 51,384.77 -
 EQUALS THE WEEKLY LOG SHEET TOTALS AS ADJUSTED.

1-26-23
 1/26/23

Richard D. Taylor
Destiny Cox

ACH PAYMENTS



P.O. NO.	VENDOR NAME	INVOICE NO	INVOICE DATE	A/P ACCR	ACCOUNT NO.	NET AMOUNT	CHECK NO	ACH PMT	ACH ACH PMT	G/L ACCOUNT DESC	BATCH INV DESCRIPTION
00000000	FLORES & ASSOCIATES, LLC	120222-123022	1/03/2023		4100-093200-9404-	20,401.60	5	Y		HRA Employer Spend	01855 SUSSEX COUNTY
		CHECK TOTAL			20,401.60	00	EPY	PMT	TOTAL	00	20,401.60
		CHECK TOTAL			20,401.60	00	EPY	PMT	TOTAL	00	20,401.60
		CHECK TOTAL			20,401.60	00	EPY	PMT	TOTAL	00	20,401.60

I HEREBY APPROVE THIS REGISTER FOR PAYMENT WITH EXCEPTIONS LISTED BELOW OR PREVIOUSLY DOCUMENTED.
 THE TOTAL 20,401.60 - EQUALS THE WEEKLY LOG SHEET TOTALS AS ADJUSTED

[Signature]
 TRENOR OF FINANCE
[Signature]
 COUNTY ADMINISTRATOR
[Signature]
 DESTE J. COX, TREASURER

1-3-23
 DATE
1-3-23
 DATE
1/3/23
 DATE

SUSSEX COUNTY
TREASURER'S REPORT
AND
FINANCIAL UPDATE

SUBMITTED BY DESTE J. COX, TREASURER

JANUARY 31, 2023



TREASURER'S OFFICE

*DESTE JARRATT COX
TREASURER
SUSSEX COUNTY*

*15074 COURTHOUSE ROAD
P.O. BOX 1399
SUSSEX, VA. 23884*

*Phone (434)246-1086 or
(434)246-1087
Fax (434)246-2347*

Statement of money in the banks to the credit of Sussex County as shown by the Treasurer's books at the close of business January 31, 2023

TRUIST #201- SUSSEX, VA

Bank Balance -----	\$39,044.63	
Bank Fees/Adjustments -----	\$170.27	
Deposits in Transit-----	(\$3,110.30)	
Outstanding Checks-----	\$0.00	\$36,104.60

BSV #301- STONY CREEK, VA

Bank Balance-----	\$12,742,357.55	
Bank Fees/Returned Checks-----	\$12.00	
Credit Card Fees/Adjustments-----	\$2,806.56	
Deposits in Transit -----	(\$23,730.09)	
Outstanding Checks-----	(\$1,090,950.72)	\$11,630,495.30

PRIMIS #401- WAVERLY, VA

Bank Balance-----	\$169,071.61	
Deposits in Transit-----	(\$7.33)	\$169,064.28
Investments and CD's-----		
#30383118 - Primis #451	\$1,021,184.88	
#30383043 - Primis #451	\$2,022,788.19	
#30390504 - Primis #451	\$2,500,000.00	
		\$5,543,973.07

<u>QZAB -06 #702</u> Investment Balance-----		0.00
<u>LGIP INVESTMENT #803</u> Investment Balance-----		2,127,230.19
<u>VA INV POOL #804</u> Investment Balance-----		146,235.40
TOTAL IN BANKS REC W/GL-----		\$19,653,102.84

Letters or statements from each of the above mentioned banks are on file in the Treasurer's Office of Sussex County certifying the balance as listed above.

Respectfully submitted:

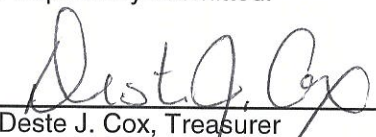

 Deste J. Cox, Treasurer

SUSSEX COUNTY - DESTE J. COX, TREASURER
REVENUE/EXPENDITURE SUMMARY REPORT
JANUARY 2023

General Fund **FUND BALANCE as of 1/31/23 = \$ 11,753,597.51**

<i>REVENUES</i>		<i>ANNUAL APPROPRIATED</i>	<i>CURRENT MONTH ACTIVITY</i>	<i>YTD ACTUAL 01/31/2023</i>	<i>PRIOR FY - YTD Through 01/31/2022</i>	<i>COLLECTED % YTD</i>
Real Estate - 2022		5,511,434	145,047	4,836,951	4,821,752	87.8%
Public Service Corp - 2022		713,720	0	726,038	728,273	101.7%
Personal Property - 2022		3,858,156	123,439	3,148,603	2,794,828	81.6%
Machinery & Tools - 2022		560,919	0	973,299	587,628	173.5%
Local Sales & Use Taxes (net)		1,040,124	86,031	647,096	636,977	62.2%
Transient Occupancy Tax		80,000	7,293	58,612	53,378	73.3%
Consumer Utility Taxes		93,000	3,754	49,895	54,754	53.7%
Business License Taxes		70,050	3,426	24,172	19,438	34.5%
Motor Vehicle Licenses		229,800	9,804	141,151	174,377	61.4%
Landfill Tipping Fees		5,550,000	470,663	3,205,994	3,235,592	57.8%
Delinquent Taxes RE		172,500	6,202	104,624	93,321	60.7%
Delinquent Tax Personal Property		88,100	4,405	64,457	58,073	73.2%
Penalties - All Property		115,000	1,069	17,412	38,180	15.1%
Interest - All Property		30,000	1,303	12,272	17,962	40.9%
Court Fines		840,000	51,119	419,903	487,766	50.0%
EMS Billing		300,000	0	6,821	n/a	2.3%
State		4,122,872	512,293	2,746,934	3,259,227	66.6%
Federal		1,500	400	600	84,077	40.0%
Transfer in from Reserve		336,770	49,165	336,770	351,047	100.0%
Designated Use of Fund Balance		3,098,739	0	0	0	0.0%
<i>EXPENDITURES</i>		<i>ANNUAL APPROPRIATED</i>	<i>CURRENT MONTH ACTIVITY</i>	<i>YTD ACTUAL 01/31/2023</i>	<i>PRIOR FY - YTD Through 01/31/2022</i>	<i>SPENT % YTD</i>
General Government		3,695,586	272,312	1,615,248	1,351,912	43.7%
Judicial Administration		1,290,437	102,219	751,750	676,469	58.3%
Fire, Rescue, EMS		2,748,996	284,524	1,753,411	1,395,753	63.8%
Sheriff's Operations & Jail		6,434,447	442,130	3,015,759	2,947,811	46.9%
Public Works		2,078,465	137,175	1,250,093	817,396	60.1%
Health & Welfare		908,783	19,887	342,649	804,633	37.7%
Education		7,750,121	608,310	3,923,844	3,822,788	50.6%
Parks Rec & Cultural Enrichment		273,760	47,565	197,445	200,973	72.1%
Planning/Community Dev		1,463,623	27,679	629,732	397,986	43.0%
Debt Service		1,581,016	116,034	1,462,065	1,392,342	92.5%

General Fund							
			ANNUAL	CURRENT	ACTUAL	YTD 01/31/2022	Spent %
EXPENDITURES BY DEPARTMENT			APPROPRIATED	ACTIVITY	YEAR TO DATE	PRIOR FISCAL YEAR	YTD
Board of Supervisors			168,687	9,137	80,097	71,344	47.5%
Administration			2,077,499	117,306	653,382	555,226	31.5%
Contingency Acct (7/1/22 = \$100,000)			21,854	0	0	0	0.0%
HRA Admin Fee			5,600	0	0	N/A	0.0%
HRA Employer Spend			160,000	20,402	126,458	N/A	79.0%
IT & Central Acct			102,093	14,383	92,193	38,296	90.3%
County Attorney			150,000	8,500	67,242	98,397	44.8%
Registrar/Board of Elections			247,538	20,856	143,178	115,564	57.8%
Com of Revenue			277,659	20,971	153,873	145,062	55.4%
Reassessment Services			48,163	233	42,063	76,787	87.3%
Treasurer			436,493	60,525	256,763	251,235	58.8%
General Government			3,695,586	272,312	1,615,248	1,351,912	43.7%
Courts			110,423	11,550	57,659	51,854	52.2%
Clerk of Courts			457,126	32,744	279,358	228,656	61.1%
Com Atty/Vic Wit			722,888	57,925	414,733	395,959	57.4%
Judicial Administration			1,290,437	102,219	751,750	676,469	58.3%
Fire/Rescue/EMS			2,237,671	249,071	1,472,555	1,166,361	65.8%
Aminal Control			511,325	35,453	280,856	229,392	54.9%
Fire, Rescue, EMS			2,748,996	284,524	1,753,411	1,395,753	63.8%
Court Sec/Spot/FO/E911			4,299,923	296,374	1,892,347	1,784,276	44.0%
Confinement of Inmates			1,979,571	138,353	1,045,936	1,099,487	52.8%
Crater Crim Justice Aca.			154,954	7,402	77,477	64,049	50.0%
Sheriff's Operations & Jail			6,434,447	442,130	3,015,759	2,947,811	46.9%
Building & Grounds			1,045,151	43,532	622,549	257,880	59.6%
Envir Inspections			197,540	9,403	71,045	93,540	36.0%
General Works			297,197	38,810	175,899	139,582	59.2%
Convenience Ctrs.			538,577	45,431	380,601	326,394	70.7%
Public Works			2,078,465	137,175	1,250,093	817,396	60.1%
Health - Outside Agencies			236,615	0	86,298	187,473	36.5%
Com. Support Services - Outside Agencies			202,815	6,176	98,683	149,287	48.7%
Local Contrib to DSS			289,353	0	47,684	223,955	16.5%
Local Contrib to CSA			180,000	13,711	109,983	243,918	61.1%
Health & Welfare			908,783	19,887	342,649	804,633	37.7%
Educ Contrib - Outside Agencies			951	0	951	2,982	100.0%
Local Contrib to Sch Fd			7,749,170	608,310	3,922,893	3,819,806	50.6%
Education			7,750,121	608,310	3,923,844	3,822,788	50.6%
Library/Cultural - Outside Agencies			204,260	47,565	148,945	152,613	72.9%
Recreational Contrib- Outside Agencies			69,500	0	48,500	48,360	69.8%
Parks Rec & Cultural Enrichment			273,760	47,565	197,445	200,973	72.1%
DHCD UNOS Grt			576,732	0	271,664	133,838	47.1%
Planning/Building/Zoning			483,630	27,679	207,880	262,873	43.0%
CDBG Pocahantas Grt			283,325	0	42,751	-54,338	15.1%
Crater Planning Com			8,771	0	8,771	4,895	100.0%
IDA			62,500	0	50,000	0	80.0%
Va Gateway Region			47,166	0	47,166	47,417	100.0%
Crater SBDC			1,500	0	1,500	3,300	100.0%
Planning/Community Dev			1,463,623	27,679	629,732	397,986	43.0%
Debt Service			1,581,016	116,034	1,462,065	1,392,342	92.5%
Debt Service			1,581,016	116,034	1,462,065	1,392,342	92.5%

**SUSSEX COUNTY
REVENUE/EXPENDITURE SUMMARY REPORT
JANUARY 2023**

Capital Projects Fund - Fund 302 **FUND BALANCE as of 01/31/23 = \$ 131,443 plus \$669,470 F&R Dedicated Funds**

<i>REVENUES</i>	<i>ANNUAL APPROPRIATED</i>	<i>CURRENT MONTH ACTIVITY</i>	<i>YTD ACTUAL 01/31/2023</i>	<i>PRIOR FY - YTD Through 01/31/2022</i>
Interest Earned	900	1,208	4,339	459
Gifts/Donations Fire & Rescue	0	0	0	0
Transfer from General Fund	0	0	0	0
Total Capital Projects Fund Revenues	900	1,208	4,339	459
<i>EXPENDITURES</i>	<i>ANNUAL APPROPRIATED</i>	<i>CURRENT MONTH ACTIVITY</i>	<i>YTD ACTUAL 01/31/2023</i>	<i>PRIOR FY - YTD Through 01/31/2022</i>
Replace E911 Equip	56,322.00	0	0	0
Voting Machines	8,625.00	0	0	0
Sheriff Patrol Vehicle	53,739.77	0	0	68,394
Transfer to Other Funds	17,626	16,726	16,726	175,054
Communications	20,000.00	0	0	0
Renovations-Co. Buildings	216,303.00	0	0	0
School Projects	27,000.00	0	0	0
Animal Shelter & Complex	0.00	0	0	0
Total Capital Projects Fund Expenditures	399,616	16,726	16,726	243,448

**SUSSEX COUNTY
REVENUE/EXPENDITURE SUMMARY REPORT
JANUARY 2023**

Reserve Fund 135 **FUND BALANCE as of 01/31/23 = \$ 5,838,590**

<i>REVENUES</i>	<i>ANNUAL APPROPRIATED</i>	<i>CURRENT MONTH ACTIVITY</i>	<i>YTD ACTUAL 01/31/2023</i>	<i>PRIOR FY - YTD Through 01/31/2022</i>
Interest	4,000	9,834	25,373	2,895
Transfer from General Fund	2,000,000	2,000,000	2,000,000	0
Total Reserve Fund Revenues	2,004,000	2,009,834	2,025,373	2,895
<i>EXPENDITURES</i>	<i>ANNUAL APPROPRIATED</i>	<i>CURRENT MONTH ACTIVITY</i>	<i>YTD ACTUAL 01/31/2023</i>	<i>PRIOR FY - YTD Through 01/31/2022</i>
Transfer to General Fund	340,770	49,165	336,770	176,020
Transfer to VPA Fund	0	0	0	579
Transfer to Cap Proj Fund	0	0	0	0
Total Reserve Fund Expenditures	340,770	49,165	336,770	176,599

BUILDING INSPECTIONS DEPARTMENT



February 23, 2023 Monthly Reports



MEMORANDUM

DATE: February 6, 2023
 TO: Richard Douglas, County Administrator
 FROM: Matt Westheimer, Building Official
 SUBJECT: January 2023 - Monthly Report

Please accept this as the January 2023 update for the Building Department.

BUILDING ACTIVITY

- January 2023

<i>Building Permits</i>	<i>Electrical Permits</i>	<i>Plumbing & Sprinkler Permits</i>	<i>Mechanical Permits</i>	<i>Field Inspections</i>	<i>Improvement Value</i>	<i>Revenue Generated</i>
13	14	6	11	50	\$1,325,811.27	\$11,018.21

- January 2022

<i>Building Permits</i>	<i>Electrical Permits</i>	<i>Plumbing & Sprinkler Permits</i>	<i>Mechanical Permits</i>	<i>Field Inspections</i>	<i>Improvement Value</i>	<i>Revenue Generated</i>
12	15	6	11	97	\$1,424,373.00	\$8,184.96

- January 2023 – December 2023 (Yearly totals)

<i>Building Permits</i>	<i>Electrical Permits</i>	<i>Plumbing & Sprinkler Permits</i>	<i>Mechanical Permits</i>	<i>Field Inspections</i>	<i>Improvement Value</i>	<i>Revenue Generated</i>
13	14	6	11	50	\$1,325,811.27	\$11,018.21

<i>Inspections completed within 24 hours For January</i>	100%
<i>Plans reviewed within 10 business days For January</i>	100%



BOARD ACTION FORM

Agenda Item: Consent Agenda Item #2.05

Subject: Waste Management Tax Refund (Finance Committee Recommendation)

Board Meeting Date: February 23 2023

=====

Summary: This item was removed from the Board’s January regular agenda to forward to the Finance Committee for discussion and or review for request for refund for Environmental equipment by Atlantic Waste Disposal filed in error to be taxed for value assessed 15,647,454 tax totaling to be \$380,233.13,

Recommendation: That the Board approves payment of refund to Atlantic Waste Disposal, C/O Marvin F. Poer & Company.

Attachment: Copy letter to the BOS from the Ellen Boone, Commissioner of the Revenue, dated January 9, 2023.

=====

ACTION: That the Board approves payment of refund to Atlantic Waste Disposal, C/O Marvin F. Poer & Company.

MOTION BY: _____ **SECONDED BY:** _____

<u>Member</u>	<u>Aye</u>	<u>Nay</u>	<u>Member</u>	<u>Aye</u>	<u>Nay</u>
Fly	___	___	W. Jones	___	___
Futrell	___	___	Seward	___	___
D. Jones	___	___	Tyler	___	___
			White (Tie Breaker)	___	___



Office of Commissioner of the Revenue
Sussex County

Ellen G. Boone
Commissioner

January 9, 2023

Sussex County Board of Supervisors
P O Box 1397
Sussex, Virginia 23884

ATTENTION: Mrs. Susan Seward, Chairperson

Dear Mrs. Seward,

For the taxable year 2022, Atlantic Waste Disposal, filed a personal property tax return with my office on April 12, 2022, listing Machinery & Tools equipment to be taxed. In December, I was notified that some of the equipment was filed in error. The company did not realize that some of the equipment listed was Pollution Control Equipment which is tax exempt.

Please refund Atlantic Waste Disposal, C/O Marvin F. Poer & Company, P O Box 52427, Atlanta Georgia, 30355, value assessed 15,647,454 tax totaling to be \$380,233.13.

Thanking you in advance, I am

Very truly yours,

Ellen G. Boone
Commissioner of the Revenue

Cc: Mrs. Deste J. Cox

P. O. Box 1398
Sussex, Virginia 23884-0398
Fax: (434) 246-4503
Email: e.boone@sussexcountyva.gov

BOARD ACTION FORM

Agenda Item: Consent Agenda Item #2.06

Subject: Sheriff's Vehicle Replacement Budget Amendment

Board Meeting Date: February 23 2023

=====

Summary: Staff recommends an appropriation of funds to be added to insurance proceeds that will allow for the replacement of two patrol vehicles for the Sheriff's Department.

Recommendation: Staff recommends the Board adopts the proposed budget amendment.

Attachment: Budget Amendment #23-12B

=====

ACTION: That the Board adopts Resolution #23-12B budget amendment

MOTION BY: _____ **SECONDED BY:** _____

<u>Member</u>	<u>Aye</u>	<u>Nay</u>	<u>Member</u>	<u>Aye</u>	<u>Nay</u>
Fly	___	___	W. Jones	___	___
Futrell	___	___	Seward	___	___
D. Jones	___	___	Tyler	___	___
			White (Tie Breaker)	___	___

BOARD ACTION FORM

Agenda Item: Consent Agenda Item #2.06

Subject: Sheriff's Vehicle Replacement Budget Amendment

Board Meeting Date: February 23 2023

=====

Summary: Staff recommends an appropriation of funds to be added to insurance proceeds that will allow for the replacement of two patrol vehicles for the Sheriff's Department.

Recommendation: Staff recommends the Board adopts the proposed budget amendment.

Attachment: Budget Amendment #23-12B

=====

ACTION: That the Board adopts Resolution #23-12B budget amendment

MOTION BY: _____ **SECONDED BY:** _____

<u>Member</u>	<u>Aye</u>	<u>Nay</u>	<u>Member</u>	<u>Aye</u>	<u>Nay</u>
Fly	___	___	W. Jones	___	___
Futrell	___	___	Seward	___	___
D. Jones	___	___	Tyler	___	___
			White (Tie Breaker)	___	___

RESOLUTION #23-12B
FY23 BUDGET AMENDMENT

BE IT RESOLVED by the Sussex County Board of Supervisors that the following budget amendment for the Sheriff's Operations & Jail be and hereby is made for the period of July 1, 2022 through June 30, 2023. This resolution will amend the budget to appropriate funds to the Sheriff's Department for vehicle acquisition.

FUND # 100
GENERAL FUND

REVENUE

Fund 135 Local Reserves	<u>\$42,992</u>
Total Revenues	\$42,992

EXPENDITURE

Fund 100 Sheriff's Operations & Jail	<u>\$42,992</u>
Total Expenditures	\$42,992

Adopted this 23rd day of February, 2023.

Wayne O. Jones, Chairman
Sussex County Board of Supervisors

ATTEST:

Shilton R. Butts, Clerk
Sussex County Board of Supervisors

BOARD ACTION FORM

Agenda Item: Consent Agenda Item #2.07

Subject: Courthouse Fire Department Extrication Equipment Purchase (Finance Committee Recommendation) with Budget Amendment

Board Meeting Date: February 23 2023

=====

Summary: Staff recommends an appropriation of ARPA funds to provide for the purchase of extrication equipment for the Courthouse Volunteer Fire Department, as discussed and recommended at the recent Finance Committee meeting.

Recommendation: Staff recommends the Board adopts the proposed budget amendment.

Attachments: Proposal: Towns of Sussex Capacity Improvement

=====

ACTION: That the Board adopts resolution budget amendment in the amount of \$7,200.00.

MOTION BY: _____ **SECONDED BY:** _____

<u>Member</u>	<u>Aye</u>	<u>Nay</u>	<u>Member</u>	<u>Aye</u>	<u>Nay</u>
Fly	___	___	W. Jones	___	___
Futrell	___	___	Seward	___	___
D. Jones	___	___	Tyler	___	___
			White (Tie Breaker)	___	___

BOARD ACTION FORM

Agenda Item: Consent Agenda Item #2.08

Subject: March 2, 2023 BOS Budget Work Session for Big Ticket Items

Board Meeting Date: February 23 2023

=====

Summary: Just a friendly reminder, a Budget Work Session has been scheduled for Thursday, March 2, 2023 for Big Ticket Items.

Location will provided at a later date.

Recommendation:

Attachment: N/A

=====

ACTION: None

MOTION BY: _____ **SECONDED BY:** _____

<u>Member</u>	<u>Aye</u>	<u>Nay</u>		<u>Member</u>	<u>Aye</u>	<u>Nay</u>
Fly	___	___		W. Jones	___	___
Futrell	___	___		Seward	___	___
D. Jones	___	___		Tyler	___	___
			White	___	___	
			(Tie Breaker)			

BOARD ACTION FORM

Agenda Item: Consent Agenda Item #2.09

Subject: Public Meeting February 27, 2023 for Sussex County Fire & EMS Study– *for information only*

Board Meeting Date: February 23 2023

=====

Summary: The Virginia Department of Fire Programs will be holding a public meeting on Monday, February 27, 2023, at 6:00 p.m. the Sussex Judicial Center – General District Court located at 15098 Courthouse Road, Sussex, Virginia 23884, to receive comments for a Fire and EMS Study for Sussex County.

Recommendation:

Attachment: N/A

=====

ACTION: None

MOTION BY: _____ **SECONDED BY:** _____

<u>Member</u>	<u>Aye</u>	<u>Nay</u>	<u>Member</u>	<u>Aye</u>	<u>Nay</u>
Fly	___	___	W. Jones	___	___
Futrell	___	___	Seward	___	___
D. Jones	___	___	Tyler	___	___
			White (Tie Breaker)	___	___

BOARD ACTION FORM

Agenda Item: Consent Agenda Item #2.10

Subject: Public Safety Coordinator Position Reclassification and VRS Change

Board Meeting Date: February 23 2023

=====

Summary: To better accommodate potential employee needs and better provide support to our volunteer fire departments, staff is requesting that the Public Safety Coordinator position be reclassified to Chief of Emergency Services (as recommended by consultant Thomas Hicks), to include an adjustment to the position annual salary (budgeted) to \$90k. In addition staff is requesting adoption of the attached resolution to make this position eligible for the enhanced state retirement benefits for hazardous positions. This shift will allow the position to assist the volunteer fire departments in a firefighting capacity and is supported by the county fire/rescue association.

Recommendation:

Attachments: Hazardous Duty Retirement Resolution #23-12F, Draft Chief of Emergency Services Job Description, and VRS Certification of Hazardous Duty Service Form

=====

ACTION: That the Board approves the Public Safety Coordinator position reclassification to Chief of Emergency to include an adjustment to the position annual salary (budgeted) to \$90k and adopts resolution to make the position eligible for the enhanced State Retirement benefits for hazardous positions.

MOTION BY: _____ **SECONDED BY:** _____

<u>Member</u>	<u>Aye</u>	<u>Nay</u>	<u>Member</u>	<u>Aye</u>	<u>Nay</u>
Fly	___	___	W. Jones	___	___
Futrell	___	___	Seward	___	___
D. Jones	___	___	Tyler	___	___
			White (Tie Breaker)	___	___

RESOLUTION 23-12F

At a regular meeting of the Sussex County Board of Supervisors held in the General District Courtroom of the Government Center on February 23, 2023 at 6:00 p.m.

PRESENT:

VOTE:

The Honorable Wayne O. Jones, Chairman

The Honorable Susan B. Seward, Vice-Chair

The Honorable C. Eric Fly

The Honorable Alfred G. Futrell

The Honorable Debbie P. Jones

The Honorable Rufus E. Tyler, Sr.

A RESOLUTION OF THE SUSSEX COUNTY BOARD OF SUPERVISORS APPROVING OF THE COUNTY’S PARTICIPATION IN THE ENHANCED HAZARDOUS DUTY BENEFITS FOR PUBLIC SAFETY TO INCLUDE LAW ENFORCEMENT AND FIREFIGHTERS FROM THE VIRGINIA RETIREMENT SYSTEM (VRS)

WHEREAS, subject to the approval of the Virginia Retirement System ("VRS") Board of Trustees, Code of Virginia § 51.1-138 permits a political subdivision of the Commonwealth of Virginia currently participating in VRS to make an irrevocable election to provide enhanced hazardous duty retirement benefits for its eligible employees as outlined in § 51.1-138; and

NOW, THEREFORE, BE IT RESOLVED, that the Sussex County, Virginia (the "Employer") does hereby elect to have such employees of Employer who are employed in positions as full time Law Enforcement, Firefighters, Emergency Medical Technicians and whose tenure is not restricted as to temporary or provisional appointment, become eligible, effective the first day of May 2023, for VRS benefits equivalent to those provided for state police officers of the Department of State Police, as set out in § 51.1-13 8 including the retirement multiplier of 1.85%, in lieu of the benefits that would otherwise be provided to such employees, and Employer agrees to pay the employer cost for providing such benefits; and

NOW, THEREFORE, the officers of Employer are hereby authorized and directed in the name of Employer to carry out the provisions of this resolution and to pay to the Treasurer of Virginia from time to time such sums as are due to be paid by Employer for this purpose.

NOW THEREFORE BE IT RESOLVED that the Sussex County Board of Supervisors, this 23rd day of February, 2023, approves of the County's participation in Enhanced Hazardous Duty Benefits for Law Enforcement Officers from the Virginia Retirement System (VRS)

Adopted February 23, 2023

Wayne O. Jones, Chairman
Sussex County Board of Supervisors

ATTEST:

Clerk to the Board of Supervisors

Resolution #23-12F
February 23, 2023
Page 2

JOB DESCRIPTION
Sussex County, VA

Job Title	Chief of Emergency Services
Department	Emergency Services Department
Category	Full Time
FSLA	Exempt
Pay Grade	
Report to:	County Administrator
Supervises:	

JOB SUMMARY/PURPOSE

The Emergency Services Chief is a county leader who serves as a key member of the Executive Leadership Team translating Board of Supervisors’ strategic plan into action through development of policies, leadership, innovation, and resource allocation and management.

The Emergency Services Chief is responsible for establishing major departmental policies, planning long-term programs, and making executive-level decisions in alignment with the direction of the organization as defined by Board of Supervisors and the County Administrator. Primary duties involve overseeing emergency management and coordinating emergency response activities in the county, including developing recommendations and plans for the protection of life and property within the community. This position also serves as a liaison to the volunteer fire and EMS departments and Sheriff’s offices to support and mitigate response along with managing portions of the radio and communication system. Work will require attending some evening meetings and occasional weekend meetings/events.

Work is performed with wide latitude for independent judgment and action, and is reviewed by the County Administrator through conferences, reports, and success of the department's programs and activities.

This position is an essential position and classified as hazardous duty as the Chief, responds, engages and mitigates active emergency incidents including fires, hazardous materials and other all hazard events.

ESSENTIAL JOB FUNCTIONS

(The essential functions or duties listed below are intended only as illustrations of the various types of work that may be performed. The omission of specific statements of duties does not exclude them from the position if the work is similar, related or a logical assignment to the position.)

- Demonstrate a high level of customer service; encourage others to focus on the customer; foster an environment where customer service is a priority

- Communicate with customers to ensure that, where possible, they are satisfied, and that their needs are being addressed; solicit and evaluate customer feedback
- Act as an ambassador by understanding and fostering the organization's mission and vision
- Exhibit pride in self, the department, the county, and the community; conduct self in a professional manner
- Demonstrate integrity and build trust through credibility, reliability, commitment, loyalty, and ethical behavior
- Address difficult or contentious issues in a constructive manner
- Support and promote change; demonstrate flexibility and take calculated risks when appropriate
- Participate in personal growth opportunities, and attend trainings designed to enhance capacity to bring new skills and ideas to the job and the organization
- Work to continuously improve the efficiency and effectiveness of the service or product being delivered
- Demonstrate support for team efforts by accepting new roles and responsibilities, and helping others achieve objectives
- Value diversity; demonstrate an awareness of differences; demonstrate sensitivity, and adapt behaviors and communication to accommodate these differences
- Manage and serve as the County's liaison with any contractual services executed through Sussex County regarding public safety to include contractual EMS services, purchase of equipment, the management of the radio system, mitigation contracts during an active emergency and other identified future public safety needs.

EXECUTIVE COMPETENCIES

- Embrace public service in the community and demonstrate a global perspective in decisions
- Communicate and collaborate with the County Administrator and Executive Leadership Team to develop innovative solutions that support and promote a high-performing organization
- Effectively participate on the Executive Leadership Team by demonstrating strategic and systemic problem-solving skills; communication, collaboration and cooperation are expectations required of leadership
- Represent the County in a professional manner and positive light
- Support and promote diversity, equity, and inclusivity
- Develop performance measures based on critical operational outcomes to meet strategic objectives
- Develop policies, procedures, and best practices that demonstrate exceptional customer service and prudent stewardship of County revenues
- Respond to contentious issues in a timely manner that reflects and supports management philosophy and decisions
- Support and encourage ongoing employee development through training, continuing education, and job-specific training
- Model and encourage employees to demonstrate ownership by fostering a collegial and supportive work environment

- Be a visible leader in Sussex County neighborhood, business, and all service communities
- Help employees and volunteers understand their part in meeting strategic goals and vision
- Encourage employees and volunteers to participate in partnerships and collaborative efforts throughout public safety
- Have a comprehensive understanding and knowledge of all elements of their department budget

Leadership/Supervisory

- Foster a participatory organizational climate that is open, positive, reinforcing, and supportive
- Encourage employees and volunteers to be accountable for their work and take ownership in what they do
- Demonstrate leadership and courage by making or supporting decisions that reflect the organizational mission and goals even when the decision may be unpopular to some
- Demonstrate collaboration and conflict resolution skills with other departments and employees
- Help employees and volunteers see the value of developing their skills, and assist them in eliminating barriers to their development; encourage employees to step outside of their comfort zone to develop their skills
- Provide meaningful, timely feedback and effectively address performance problems
- Effectively supervise, mentor, and motivate in a team environment relationship with colleagues which encourage constructive feedback and new ways to look at projects, policies, service delivery, etc.

Job Specific

- Demonstrate extensive knowledge of:
 - the principles, practices, and techniques of modern emergency management, prevention, and emergency medical response, and ability to apply this knowledge to varied fire control, prevention, EMS, and administrative problems
 - the principles and practices for the operation, capabilities, and maintenance of the various types of apparatus and equipment used in public safety
 - the rules and regulations of the department, county and state laws and ordinances
 - the principles of public administration with reference to personnel administration, budget preparation and administration, and overall management concepts
 - current literature, research, and developments in the fields
- Plan, initiate, carry out, and follow up on programs in administration, training, prevention, and operations

- Respond too and provide operational support on active emergency incidents to include, fires, EMS calls, accidents, hazardous materials, and other all hazard emergencies.
 - Supervises both short-range and long-range implementation of plans
 - Purchases and approves purchase of departmental materials, supplies and equipment
 - Maintains and improves public safety response in order to fulfill safe community strategic objective
4. Driving is essential to this position; must operate County and personal vehicles in a safe manner
6. Maintains regular and punctual attendance

Other Duties and Responsibilities

Attends some of the regular evening Board meetings and study sessions; may attend evening or weekend community meetings. Incumbent is accountable for all duties of this job, and other projects and responsibilities may be added at the County’s discretion.

MINIMUM REQUIREMENTS TO PERFORM WORK

Education and Experience:

- Bachelor’s Degree from an accredited university or college with major coursework in Public Administration, Fire Administration, or a related field
- Supervisory experience at the Battalion Chief level or above
- Experience in emergency management, prevention, emergency medical response, and emergency preparedness, in any combination
- Maintain a valid driver's license and safe driving record throughout employment
- Minimum five (5) years of senior management and administrative experience in a public sector or military setting, or four (4) years of experience in an executive-level city management position combined with public sector experience

Any equivalent combination of education, training, and experience, which would provide the required knowledge and skills, may be considered.

Minimum Operational Licenses or Certificates required for employment:

- Federal and/or State Emergency Management Certifications
- NIMS 100, 200, 700, 800
- Current certification as Emergency Medical Technician (EMT)
- EVOC – Emergency Vehicle Operations Course
- Current CPR card
- Valid driver’s license in the Commonwealth of Virginia along with a good driving record
- Firefighter I and II and Hazardous Materials Operations certifications

- Other required certification mutually agreed upon by the Chief and County Administrator.

PRE-EMPLOYMENT REQUIREMENTS

- Background checks will include employment references and criminal history, credit check, driver's license record, and education verification
- Pre-employment drug screen
- Must be legally entitled to work in the United States

(This job description does not constitute an employment agreement between the employer and employee. It is used as a guide for personnel actions and is subject to change by the employer as the needs of the employer and requirements of the job change).

Draft

CERTIFICATION OF HAZARDOUS DUTY SERVICE



VIRGINIA RETIREMENT SYSTEM
 P.O. Box 2500 ♦ Richmond, VA 23218-2500
 Toll-free 1-888-827-3847
 Fax 804-786-9718
 www.varetire.org

1. Social Security Number
2. Date

Complete this form for employees who become employed in a position from which they can retire under the Virginia Law Officers' Retirement System (VaLORS), the State Police Officers' Retirement System (SPORS), or VRS with enhanced benefits for hazardous duty positions. This form is used to certify service eligible for the hazardous duty supplement.

Include employment prior to October 1, 1999 in the following positions:

- Police Officer in the Capitol Police Force (§ 30-34.2:1)
- Police Officer on campus at an institution of higher education (§ 23.1-809)
- Conservation Police Officer in the Department of Wildlife Resources (§ 29.1-200)
- Special Agent for the Virginia Alcoholic Beverage Control Authority (§ 4.1-100)
- Marine Resource Law Enforcement Officer (§ 9.1-101)
- Correctional Officer (§ 53.1-1), including correctional officers employed at a juvenile correction facility (§ 66-25.3)
- Parole Officer (§ 53.1-143)
- Commercial Vehicle Enforcement Officer employed by the Department of State Police

Include any employment as an employee of a VRS-participating political subdivision employed in one of the following positions:

- Police Officer (law-enforcement position comparably hazardous to that of a state police officer including any sworn law enforcement officer who has the duty and obligation to enforce the penal and traffic laws of the Commonwealth as directed by a superior officer)
- Full-time salaried Fire Chief, Firefighter or full-time salaried Emergency Medical Technician (EMT)
- Regional Jail Superintendent or Jailer for a regional jail farm, regional jail or jail authority
- Sheriff or Deputy Sheriff

EMPLOYER HUMAN RESOURCES CERTIFICATION

Member Name (First, Middle Initial, Last)			
Certification: I certify this VRS member worked in a hazardous duty position during the following time period(s):			
VRS Job Name (as indicated above) *	From (mm/yyyy)	Through (mm/yyyy)	Mos in Period
_____	_____	_____	_____
_____	_____	_____	_____
_____	_____	_____	_____
Authorized Signer (Printed Name)		Total Haz Months Certified: _____	
Authorized Signature		Authorized Signer's Title	
Employer Name		Employer Code Where Service Rendered	

* VRS job name in myVRS Navigator will be updated by VRS if necessary.



BOARD ACTION FORM

Agenda Item: Consent Agenda Item #2.11

Subject: Berkley Group Emergency Management Support Services Budget Amendment

Board Meeting Date: February 23 2023

=====

Summary: Thomas Hicks with the Berkley Group, who is providing interim public safety services for the County, will provide recommendations on County EMS operations, to include a recommended EMS operations plan to provide a framework for moving the county forward. The board may wish to consider adoption of this recommended plan or use it as part of its decision making process.

Document provided at the Board meeting

Recommendation:

Attachment: Resolution #23-12G

=====

ACTION: TBD

MOTION BY: _____ **SECONDED BY:** _____

<u>Member</u>	<u>Aye</u>	<u>Nay</u>	<u>Member</u>	<u>Aye</u>	<u>Nay</u>
Fly	___	___	W. Jones	___	___
Futrell	___	___	Seward	___	___
D. Jones	___	___	Tyler	___	___
			White (Tie Breaker)	___	___

RESOLUTION #23-12G
FY23 BUDGET AMENDMENT

BE IT RESOLVED by the Sussex County Board of Supervisors that the following budget amendment for the Fire, Rescue, & Emergency Services department be and hereby is made for the period of July 1, 2022 through June 30, 2023. This resolution will appropriate local reserve funds for emergency management support services through Berkley.

FUND # 100
GENERAL FUND

REVENUE

Fund 135 Local Reserves	<u>\$8,400</u>
Total Revenues	\$8,400

EXPENDITURE

Fund 100 Emergency Services	<u>\$8,400</u>
Total Expenditures	\$8,400

Adopted this 23rd day of February, 2023.

Wayne O. Jones, Chairman
Sussex County Board of Supervisors

ATTEST:

Shilton R. Butts, Clerk
Sussex County Board of Supervisors



February 7, 2023

Sussex County
Attn: Mr. Richard Douglas
20135 Princeton Rd.
Sussex, VA 23884

RE: Work Order #11: Emergency Management Support Services

Dear Mr. Douglas:

We are pleased to present the associated scope and fee to provide emergency management support services for Sussex County. If you or your staff have any questions related to the scope and associated fee, please feel free to contact me at any time.

Thank you for the opportunity to work with you and your staff.

Sincerely,

A handwritten signature in cursive script, appearing to read "Andrew D. Williams".

Andrew D. Williams, AICP
Chief Executive Officer

I have reviewed the scope and fee for the associated work order and I hereby give the consultant notice to proceed for the work described herein.

Mr. Richard Douglas, County Administrator

Date

I. SCOPE OF SERVICES

The Berkley Group will provide emergency management support services to Sussex County. We anticipate that these services will focus on the department's retirement services/offerings, strategic coordination support for the County's EMS/ambulance services and acting as the liaison with VDEM. The individual assigned to this project is Mr. E. Thomas Hicks III, Executive Manager.

Assumptions

1. **Contact Person:** The County will provide one (1) contact person to coordinate interview dates and times with Berkley Group staff.
2. **COVID-19:** Berkley Group staff will adhere to all public health best practices as recommended by the Center for Disease Control (CDC) or state/local regulations, whichever is more stringent.

II. TERM OF SERVICE

Beginning no earlier than February 13, 2023, it is anticipated that Mr. Hicks will be available to provide up to 15 hours of on-site and off-site work per week, as needed. This work order will remain in effect until April 30, 2023.

III. FEE

The cost to provide these services will be charged at a rate of \$120/hour. Lodging and mileage will be invoiced at the active IRS reimbursement rate to and from Mr. Hick's residence in Kinsale, Virginia. Payment will be made to The Berkley Group and invoiced monthly.

BOARD ACTION FORM

Agenda Item: Consent Agenda Item #2.12

Subject: CHA Landfill Budget Amendment

Board Meeting Date: February 23 2023

=====

Summary: This resolution will appropriate local reserve funds for landfill inspection services through CHA.

Recommendation:

Attachment: Resolution #23-12H

=====

ACTION: TBD

MOTION BY: _____ **SECONDED BY:** _____

<u>Member</u>	<u>Aye</u>	<u>Nay</u>	<u>Member</u>	<u>Aye</u>	<u>Nay</u>
Fly	___	___	W. Jones	___	___
Futrell	___	___	Seward	___	___
D. Jones	___	___	Tyler	___	___
			White (Tie Breaker)	___	___

RESOLUTION #22-12H
FY23 BUDGET AMENDMENT

BE IT RESOLVED by the Sussex County Board of Supervisors that the following budget amendment for the Public Works function be and hereby is made for the period of July 1, 2022 through June 30, 2023. This resolution will appropriate local reserve funds for landfill inspection services through CHA.

FUND # 100
GENERAL FUND

REVENUE

Fund 135 Local Reserves	<u>\$5,000</u>
Total Revenues	\$5,000

EXPENDITURE

Fund 100 Administration	<u>\$5,000</u>
Total Expenditures	\$5,000

Wayne O. Jones, Chairman
Sussex County Board of Supervisors

ATTEST:

Shilton R. Butts, Clerk
Sussex County Board of Supervisors

Adopted this 23rd day of February, 2023.

BOARD ACTION FORM

Agenda Item: Consent Agenda Item #2.13

Subject: Economic Development Planning Grant to Assist Sussex County Towns Budget Amendment

Board Meeting Date: February 23 2023

=====

Summary: At the January 19, 2023, the Sussex County Board of Supervisors approved a proposal submitted by Mr. Jeff Sadler (Complete Community Economies) to identify areas of need to accommodate future economic growth in the County and garner federal and/or state support for capacity building in all four Towns to address those identified needs and capitalize on growth. Mr. Sadler will research current conditions and identify a few attainable goals that will build the ability of the four Towns and other parts of the County to address their current and future needs. These goals will be part of a basic plan built around Town revitalization and used to apply for state/federal grants. The total cost for this approved proposal is \$7,200.00.

The attached document contains Mr. Sadler’s proposal and resume.

Recommendation: Staff recommends the Board adopt the proposed budget amendment.

Attachments: Proposal: Towns of Sussex Capacity Improvement
Minutes excerpt from the January 19, 2023 Board meeting

=====

ACTION: That the Board adopts resolution budget amendment in the amount of \$7,200.00.

MOTION BY: _____ **SECONDED BY:** _____

<u>Member</u>	<u>Aye</u>	<u>Nay</u>	<u>Member</u>	<u>Aye</u>	<u>Nay</u>
Fly	___	___	W. Jones	___	___
Futrell	___	___	Seward	___	___
D. Jones	___	___	Tyler	___	___
			White (Tie Breaker)	___	___

At a Regular Meeting of the
Sussex County Board of Supervisors
Held in the General District Courtroom on
Thursday, January 19, 2023 at 6 pm

Action Item 6.01

6.01 Sussex County Towns Economic Development Planning Grant – Jeff Sadler

An opportunity for consultant services recently arose through a conversation with Jeff Sadler of Complete Community Economies. Mr. Sadler is the consultant advising the Town of Waverly on several economic development efforts, including the Town's new Revolving Loan Fund and its recent Industrial Revitalization Fund (IRF) grant award to repurpose and revitalize several decades-long vacant buildings in downtown Waverly for a brewery.

The proposed work would include identification of areas of need to accommodate future economic growth in Sussex County and garner federal and/or state support for capacity building in all four Towns to address those identified needs and capitalize on growth. There are state and federal resources available to build and support stakeholder led community improvement efforts; however, the applications for such resources require submitting some sort of basic community plan. This proposal is to research current conditions and identify a few attainable goals that will build the ability of the four Towns to address their current and future needs. These goals will be part of a very basic plan built around Town revitalization and used to apply for state and federal grants to begin addressing the needs.

Given the Board's recent discussion of efforts to engage with and promote opportunities in all four of its Towns, this proposal could be an appropriate vehicle to address that goal in a comprehensive way.

County Administrator Douglas noted the Budget Amendment would be on the February Consent Agenda.

Staff recommends the Board of Supervisors accept the proposal submitted by Mr. Sadler.

The Proposal for the Towns of Sussex Capacity Improvement including Mr. Sadler's resume was provided in the Board packet.

ON MOTION OF SUPERVISOR FLY, seconded by SUPERVISOR TYLER and carried:
RESOLVED that the Sussex County Board of Supervisors hereby approves Proposal: Towns of Sussex Capacity Improvement. All Board members present voted aye.

BOARD ACTION FORM

Agenda Item: Consent Agenda Item #2.14

Subject: Courthouse Renovation Project Budget Amendment

Board Meeting Date: February 23 2023

=====

Summary This resolution will appropriate local reserve funds to The Wooten Company for Phase 2 of the courthouse analysis renovation project.

Recommendation: Staff recommends the Board adopt the proposed budget amendment.

Attachments: Budget Amendment Resolution #23-12J

=====

ACTION: That the Board adopts resolution budget amendment #23-12J.

MOTION BY: _____ **SECONDED BY:** _____

<u>Member</u>	<u>Aye</u>	<u>Nay</u>	<u>Member</u>	<u>Aye</u>	<u>Nay</u>
Fly	___	___	W. Jones	___	___
Futrell	___	___	Seward	___	___
D. Jones	___	___	Tyler	___	___
			White (Tie Breaker)	___	___

RESOLUTION #23-12J
FY23 BUDGET AMENDMENT

BE IT RESOLVED by the Sussex County Board of Supervisors that the following budget amendment for the Administration department be and hereby is made for the period of July 1, 2022 through June 30, 2023. This resolution will appropriate local reserve funds to The Wooten Company for Phase 2 of the courthouse analysis renovation project.

FUND # 100
GENERAL FUND

REVENUE

Fund 135 Local Reserves	<u>\$100,000</u>
Total Revenues	\$100,000

EXPENDITURE

Fund 100 Administration	<u>\$100,000</u>
Total Expenditures	\$100,000

Adopted this 23rd day of February 2023.

Wayne O. Jones, Chairman
Sussex County Board of Supervisors

ATTEST:

Shilton R. Butts, Clerk
Sussex County Board of Supervisors

BOARD ACTION FORM

Agenda Item: Appointments #5.01

Subject: Appointment to District 19 Community Services Board

Board Meeting Date: February 23 2023

=====

Summary: There is a vacancy on the District 19 Community Services Board. A new appointment will need to be made. **Per D19 CSB, this appointment does not have to be the Director of Social Services.** The position description is included. The new appointment will be a three year term, starting immediately, expiring February 28, 2026 should the appointment be made at the February meeting. (The three year term will be determined by the month of the appointment per D19 CSB.)

Recommendation: That the Board appoints a representative for Sussex County to the District 19 Community Services Board with a term beginning immediately, expiring February 28, 2026.

Attachments: (1) Board member position description; (2) By Laws; and (3) Meeting Schedule

=====

ACTION: That the Board appoints a representative for Sussex County to the District 19 Community Services Board with a term beginning immediately, expiring February 28, 2026.

MOTION BY: _____ **SECONDED BY:** _____

<u>Member</u>	<u>Aye</u>	<u>Nay</u>	<u>Member</u>	<u>Aye</u>	<u>Nay</u>
Fly	___	___	W. Jones	___	___
Futrell	___	___	Seward	___	___
D. Jones	___	___	Tyler	___	___

White (Tie Breaker) ___ ___

District 19 Community Services Board Board Member Position Description

The purpose of this Community Services Board (referred to as the Board) shall be to be responsible to the cities of Colonial Heights, Emporia, Hopewell, Petersburg, and the counties of Greensville, Prince George, Sussex and Surry, Virginia, in establishment and operation of Community Mental Health, Developmental, and Substance Use programs provided for by the Chapter 5, of Title 37.2 of the Code of Virginia (1950) as amended.

The Board, as a direct agent of the governmental entities which have established it, shall be subject to the laws and regulations relating to such agencies of those governments and shall have the general powers, duties and responsibilities of a Board as outlined in Chapter 5 of Title 37.2-504, Code of Virginia.

Duties and Expectations for Members of the District 19 CSB Board of Directors

Executive Director as chief executive officer, reports directly to Board and implements all policy, financial and regulatory requirements, directs operations, staffing, service delivery, contracting, and all aspects of the Board.

In collaboration with the Executive Director, members of the Board provide oversight and assurance of the following:

- To review and evaluate all existing and proposed services and facilities available to serve the community.
- Review and approve the performance contract as required by DBHDS.
- Make policies or regulations concerning the delivery of services and operation of facilities under its direction or supervision, subject to applicable policies and regulations adopted by the Board.
- Appoint an Executive Director of community mental health, developmental, and substance use services, who meets the minimum qualifications established by the Department, and prescribe his/her duties.
- Ensure establishment of a reimbursement system to maximize the collection of fees from individuals receiving services under its jurisdiction or supervision, consistent with the provisions of § 37.2-511, and from responsible third party payors.
- Take all necessary and appropriate actions to maximize the involvement and participation of individuals receiving services and family members of individuals receiving services in policy formulation and services planning, delivery, and evaluation.
- Assure quality services and funding compliance with federal, state and local mandates and priorities.
- Chair of the Board signs Performance Contract with state agency for state funds and obligations and provider agreements with Medicaid agencies or designees as required.
- Advocates for services and funding to support needed services within the community, to local and state officials.
- Board members as local officials are must comply with FOIA, COIA, HIPAA, and all other regulations.
- Board members will comply with duties and responsibilities per the Board of Directors by-laws.

Qualifications:

Per § 37.2-50, Appointments to the community services board shall be broadly representative of the community. One-third of the appointments to the board shall be individuals who are receiving or who have received services or family members of individuals who are receiving or who have received services, at least one of whom shall be an individual receiving services. One or more appointments may be nongovernmental service providers. Sheriffs or their designees also shall be appointed, when practical. No employee of the community services board or employee or board member of an organization that receives funding from any community services board shall be appointed a member of that board. No community services board shall be composed of a majority of local government officials, elected or appointed, as members, nor shall any county or city be represented on a board by more than two officials, elected or appointed.

Attendance and Participation:

- Attend and actively participate in (8 monthly meetings on the 4th Thursday of the month, except June, July, August and November) per the by-laws. A member is responsible for notifying the Clerk of the Board in the event of an absence, it at all possible. Because representation from each locality is important, and decisions can only be made with a quorum of members present, Board Members must commit their time and travel to attend these meetings.
- Attend new board member orientation (approximately 1 hour) with executive director before attending first board meeting.
- Attend and actively participate in planning retreat (as needed).
- Attend and participate in telephone, webcam or zoom conference in between regularly scheduled meetings as needed.
- Board members are strongly encouraged to participate in additional events such as D19 All Staff meetings, public budget hearings, County Board of Supervisors meeting, City Council meetings, and advocacy opportunities throughout the year.

Compensation/Employment:

- Board members are to be compensated \$50.00 (not to exceed \$600.00 per calendar year) for attending regularly scheduled board meetings. Board members will be reimbursed for mileage at the rate approved within the Commonwealth of Virginia's Appropriation Act. Members will have the right to accept or decline compensation and/ or reimbursement for mileage. If members should decline the acceptance of payment for board meeting attendance and/or mileage reimbursement, these funds will be returned to the general fund.
- Board members are not employees of District 19 Community Services Board.

**DISTRICT 19
COMMUNITY SERVICES BOARD

BY-LAWS**

ARTICLE I - NAME

The name of this board shall be District 19 Community Services Board, hereinafter referred to as the "Board".

ARTICLE II - PURPOSE

The purpose of this Board shall be to be responsible to the cities of Colonial Heights, Emporia, Hopewell, Petersburg and the counties of Prince George, Sussex, Greensville, Dinwiddie and Surry, Virginia, in the establishment and operation of community Mental Health, Developmental, and Substance Abuse programs as provided for by the Chapter 5, of Title 37.2 of the Code of Virginia (1950) as amended.

To provide a system of comprehensive community mental health, developmental, and substance abuse services which relate to and are integrated with existing and planned programs within the limits of aforesaid jurisdictional boundaries.

ARTICLE III - MEMBERSHIP

Section 1. The membership of the Board shall consist of not less than six or more than eighteen persons approved and appointed by the governing bodies of District 19. The membership shall be as broadly representative as possible of all lay and professional elements of the community. Members shall be appointed in accordance with Chapter 5 of Title 37.2-501 of the Code of Virginia as amended.

Section 2. Board Composition shall be based on the population of each of our localities determined every 4 years. Localities with less than 15,000 citizens will be allocated one board member; localities with populations between 15,000 and 30,000 will be allocated two board members; and localities with populations exceeding 30,000 will be allocated three board members.

Section 3. A member of the Board shall be appointed for a term of three years from the first day of January of the year of appointment, or at the option of the governing body of a county or city, from the first day of July of the year of appointment.

Section 4. Vacancies shall be filled for the unexpired terms in the same manner as the original appointment.

Section 5. Ex-officio members may be appointed by this Board. Such members shall serve in an advisory capacity with no voting privilege.

Section 6. Any member of the board who is absent from two (2) consecutive regular board meetings, unless absent for reasons considered valid by the Board, shall be reminded by letter of the importance of their presence and input to the Board and further, copy of such letter shall be sent to the Chairman of the appointing County Board or Mayor of the City represented and to the appropriate County or City Administrator. A member is responsible for notifying the administrative office in the event of an absence, if at all possible.

Valid reasons for not attending a Board meeting are as follows:

- Own illness
- Family illness
- Primary job/business responsibility
- Out of town/country on business
- Out of town/country on family matter
- Out of town/country on vacation
- Other commitment, i.e., conflicting meeting, training, school
- Family commitment, i.e., child care, out-of-town guests
- Adverse weather conditions

Section 7. Board members are to be compensated \$50.00, not to exceed \$600.00 per calendar year, for attending regularly scheduled board meetings and to be reimbursed for mileage at the rate approved within the Commonwealth of Virginia's Appropriation Act. Members will have the right to accept or decline compensation and/ or reimbursement for mileage. If members should decline the acceptance of the \$50 payment and/ or mileage reimbursement, these funds will be returned to the general fund.

ARTICLE IV - POWERS AND DUTIES

The Board, as a direct agent of the governmental entities which have established it, shall be subject to the laws and regulations relating to such agencies of those governments and shall have the general powers, duties and responsibilities of a Board as outlined in Chapter 5 of Title 37.2-504, Code of Virginia. As set forth in the Code of Virginia these are:

- a. To review and evaluate all existing and proposed public community mental health, developmental, and substance abuse services and facilities available to serve the community and such private services and facilities as receive funds through the Board and advise the appropriate local governments as to its findings.

b. Pursuant to § 37.2-508, submit to the governing body of each city or county that established it a performance contract for community mental health, developmental, and substance abuse services for its approval prior to submission of the contract to the Department.

c. Within amounts appropriated for this purpose, provide services authorized under the performance contract.

d. In accordance with its approved performance contract, enter into contracts with other providers for the delivery of services or operation of facilities.

e. In the case of operating and administrative policy boards, make policies or regulations concerning the delivery of services and operation of facilities under its direction or supervision, subject to applicable policies and regulations adopted by the Board.

f. Appoint an executive director of community mental health, developmental, and substance abuse services, who meets the minimum qualifications established by the Department, and prescribe his duties.

g. Prescribe a reasonable schedule of fees for services provided by personnel or facilities under the jurisdiction or supervision of the board and establish procedures for the collection of those fees. All fees collected shall be included in the performance contract submitted to the local governing body or bodies pursuant to subdivision 2 and § 37.2-508 and shall be used only for community mental health, developmental, and substance abuse services purposes. Every board shall institute a reimbursement system to maximize the collection of fees from individuals receiving services under its jurisdiction or supervision, consistent with the provisions of § 37.2-511, and from responsible third party payors. Boards shall not attempt to bill or collect fees for time spent participating in commitment hearings for involuntary admissions pursuant to Article 5 (§ 37.2-814 et seq.) of Chapter 8.

h. Accept or refuse gifts, donations, bequests, or grants of money or property from any source and utilize the same as authorized by the governing body or bodies of each city or county that established it.

i. Seek and accept funds through federal grants; provided, however, in accepting such grants the Board shall not bind the governing body or bodies of the political subdivision or subdivisions of which it is an agency to any expenditures or conditions of acceptance without the prior approval of such governing body or bodies.

j. Notwithstanding any provision of law to the contrary, to disburse funds appropriated to it in accordance with such regulations as may be established by the governing body of the political subdivision of which the Board is an agency or, in the case of a joint board, as may be established by agreement.

k. Apply for and accept loans as authorized by the governing body of each city or county that established it.

l. Develop joint written agreements, consistent with policies adopted by the Board, with local school divisions; health departments; boards of social services; housing agencies, where they exist; courts; sheriffs; area agencies on aging; and regional offices of the Department for Aging and Rehabilitative Services. The agreements shall specify the services to be provided to individuals. All participating agencies shall develop and implement the agreements and shall review the agreements annually.

m. Develop and submit to the Department the necessary information for the preparation of the Comprehensive State Plan for Behavioral Health and Developmental Services pursuant to § 37.2-315.

n. Take all necessary and appropriate actions to maximize the involvement and participation of individuals receiving services and family members of individuals receiving services in policy formulation and services planning, delivery, and evaluation.

o. Institute, singly or in combination with other community services boards or behavioral health authorities, a dispute resolution mechanism that is approved by the Department and enables individuals receiving services and family members of individuals receiving services to resolve concerns, issues, or disagreements about services without adversely affecting their access to or receipt of appropriate types and amounts of current or future services from the community services board.

p. In the case of an operating board, have authority, notwithstanding any provision of law to the contrary, to receive state and federal funds directly from the Department and act as its own fiscal agent, when authorized to do so by the governing body of each city or county that established it.

q. Notwithstanding the provisions of § 37.2-400 or any regulations adopted thereunder, release data and information about each individual receiving services to the Department so long as the Department implements procedures to protect the confidentiality of that data and information.

ARTICLE V - OFFICERS OF THE BOARD AND THEIR DUTIES

Section 1. The officers of the Board shall consist of a Chair, Vice-Chair, and Treasurer who shall be elected by the Board and serve at the pleasure of the Board.

Section 2. The duties of the **Chair** shall be:

- a. To preside at all meetings of the Board.

- b. To appoint all committees deemed necessary for operation of the Board.
- c. To work closely with the Director of the Community Services Board.
- d. To perform any other duties determined by the Board.
- e. To keep the Department informed of the activities of the Board in the event the Executive Director's position becomes vacant.

Section 3. The **Vice-Chair** shall, in the absence of the Chair, perform the duties of the Chair and any other duties assigned by the Board.

Section 4. The **Treasurer** shall receive all philanthropic funds designated to the Board.

- a. Present a financial statement as requested by the Board and shall make a full report of the philanthropic funds at the annual meeting of the Board.

ARTICLE VI - NOMINATION, ELECTIONS AND TERMS OF OFFICE

Section 1. The Chair shall appoint a Nominating Committee at the regular scheduled October meeting. It shall be the duty of the Nominating Committee to nominate candidates for office to be elected at the January meeting. Additional nominations shall be accepted from the floor with the consent of the nominee.

Section 2. The Board shall elect its officers at the first meeting held in the new calendar year.

Section 3. The term of office shall be for one year. A quorum must be present and voting in order to constitute an election.

Section 4. Any vacancy occurring in the officers shall be filled by the Board.

ARTICLE VII - MEETINGS

Section 1. Eight scheduled meetings shall be held during the course of the year in September, October, December, January, February, March, April, and May.

Section 2. Special meetings of the Board may be called upon twenty-four hours notice by the Chairman or upon written request of three members. An attempt shall be made to notify all Board members twenty-four hours prior to special meetings in writing or by phone call.

Section 3. The quorum for all Board meetings shall be a majority of its members including the Chair or Vice-Chair.

Section 4. If a quorum is not present, the chair waits a reasonable time until there is one; or, after a reasonable time and there appears to be no prospect that a quorum will assemble, the chair will call the meeting to order and entertain a motion to adjourn.

Section 5. Public comment. All persons addressing the Board shall sign-in with name and address. Comments shall be limited to five minutes. No person shall be permitted to address the Board of Directors a second time until all others have been heard, and no one may speak more than twice on any subject in any one meeting. All remarks shall be addressed to the Board as a body. Any person who makes personal, impertinent, abusive, or slanderous statements, or incites disorderly conduct will be asked to leave the premises.

ARTICLE VIII - COMMITTEES

The Executive Director shall serve as an ex-officio member of all committees.

There shall be the following committees:

1. **Finance Committee:** This committee will work with the Executive Director in developing recommendations to the Board concerning financial matters requiring action.
2. **Personnel Committee:** This committee shall work with the Executive Director in developing and implementing personnel policies as approved by the Board and may make recommendations to the Board in personnel matters requiring action.
3. **Services Committee:** This committee will work with the Executive Director in conducting periodic needs assessments within the communities served by District 19 CSB and recommending to the Board an array of services to address these needs.
4. The Chair may appoint Ad Hoc committees as needed.

ARTICLE IX

Roberts Rules of Order, revised, shall govern the Board in all cases to which they are applicable and in which they are not inconsistent with these By-Laws.

ARTICLE X

These By-Laws may be amended at any regular meeting of the Board by two-thirds vote of those present and voting, notice having been submitted in writing, to each Board member, two weeks prior to the meeting.

Adopted at a regular meeting of the Board January 13, 1986, by a vote of 14 in favor, 0 not in favor.

Revised By-Laws and amendment to Article VIII adopted at a regular meeting of the Board March 23, 1995 by a vote of 11 in favor, 0 not in favor.

Amendment to Article VIII adopted at a regular meeting of the Board January 25, 1996 by a vote of 11 in favor, 0 not in favor.

Amendment to Article III, Section 6 adopted at a regular meeting of the Board October 24, 1996 by a vote of 12 in favor, 0 not in favor.

Amendment to Article III, Section 7 adopted at a regular meeting of the Board October 24, 1996 by a vote of 11 in favor, 1 not in favor.

Amendment to Article VII, Section 3 adopted at a regular meeting of the Board October 24, 1996 by a vote of 12 in favor, 0 not in favor.

Amendment to Article V, Section 2, and Section 4 adopted at a regular meeting of the Board October 28, 2004 by a vote of 10 in favor, 0 not in favor.

Amendment to Articles V, VII, and VIII adopted at a regular meeting of the Board March 26, 2009 by a vote of 11 in favor, 0 not in favor.

Amendment to Articles II, III and IV adopted at a regular meeting of the Board March 25, 2010 by a vote of 15 in favor, 0 not in favor.

Amendment to Articles VI and VII adopted at a regular meeting of the Board on October 28, 2010 by a vote of 13 in favor, 0 not in favor.

Amendment to Articles VI adopted at a regular meeting of the Board on December 2, 2010 by a vote of 15 in favor, 0 not in favor.

Amendment to Articles II, IV, and VIII February 27, 2020 by a vote of _____

Chair (Date)

Jennifer Tunstall Executive Director (Date)

Board of Directors Meeting Schedule for 2023

District 19 CSB Board of Directors meet the 4th Thursday of every month. We meet the first Thursday in December. The Board does not meet during the summer months of June, July, and August. We do not meet in November due to the Thanksgiving holiday. Meetings start promptly at 6:00 p.m.

January 26, 2023

February 23, 2023

March 23, 2023

April 27, 2023

May 25, 2023

September 28, 2023

October 26, 2023

December 7, 2023

BOARD ACTION FORM

Agenda Item: Action Item #6.01

Subject: VEDP Virginia Business Ready Sites Program Overview and Related Budget Amendments

Board Meeting Date: February 23 2023

=====

Summary: Sussex County was awarded \$247,900 and \$61,050 from the Virginia Economic Development Partnership (VEDP) and the Tobacco Region Revitalization Commission (TRRC), respectively, for various master planning and conceptual engineering design activities to advance the shovel-readiness of the Sussex Mega Site. A local match of \$61,050 is required; however, staff recommends the Board appropriate an additional \$35,000 for two activities VEDP inadvertently omitted from the approved program. This projects is intended to be managed through the County’s existing relationship with Virginia’s Gateway Region, Spectrum Growth Solutions, and the County’s on-call engineering firms. Because these are reimbursable grants, two budget amendments are needed to appropriate (1) \$405,000 for the full cost of the project and (2) \$15,000 for continuation of Spectrum Growth Solutions’ services to the County for 2023.

Recommendation: Staff recommends the Board adopts the proposed budget amendments.

Attachments: Budget Amendment Resolutions, VEDP VBRSP Award Letter, TRRC Award Letter, and Project Budget

=====

ACTION: That the Board adopts Resolutions #23-14 for the VEDP VBRSP Sussex Mega Site Development Grant FY23 and Resolution #23-15 for continuation of Spectrum Growth Solutions.

MOTION BY: _____ **SECONDED BY:** _____

<u>Member</u>	<u>Aye</u>	<u>Nay</u>	<u>Member</u>	<u>Aye</u>	<u>Nay</u>
Fly	___	___	W. Jones	___	___
Futrell	___	___	Seward	___	___
D. Jones	___	___	Tyler	___	___
			White (Tie Breaker)	___	___

RESOLUTION #23-14
FY23 BUDGET AMENDMENT

BE IT RESOLVED by the Sussex County Board of Supervisors that the following budget amendment for the Mega Site (Fund#305) be and hereby is made for the period of July 1, 2022 through June 30, 2023. This resolution will approve and appropriate funds for the VEDP VBRSP Sussex Mega Site Development Grant FY23.

FUND # 100
GENERAL FUND

REVENUE

Fund 305 VEDP	\$247,900
Fund 305 TRRC	\$61,050
Fund 135 Local Reserves	<u>\$96,050</u>
Total Revenues	\$405,000

EXPENDITURE

Fund 305 Mega Site	<u>\$405,000</u>
Total Expenditures	\$405,000

Adopted this 23rd day of February, 2023.

Wayne O. Jones, Chairman
Sussex County Board of Supervisors

ATTEST:

Shilton R. Butts, Clerk
Sussex County Board of Supervisors

RESOLUTION #23-15
FY23 BUDGET AMENDMENT

BE IT RESOLVED by the Sussex County Board of Supervisors that the following budget amendment for the General Government Administration function be and hereby is made for the period of July 1, 2022 through June 30, 2023. This resolution will appropriate local reserve funds to contract with Spectrum Growth Solutions.

FUND # 100
GENERAL FUND

REVENUE

Fund 135 Local Reserves	<u>\$15,000</u>
Total Revenues	\$15,000

EXPENDITURE

Fund 100 Administration	<u>\$15,000</u>
Total Expenditures	\$15,000

Adopted this 23rd day of February 2023.

Wayne O. Jones, Chairman
Sussex County Board of Supervisors

ATTEST:

Shilton R. Butts, Clerk
Sussex County Board of Supervisors

January 19, 2023

J. David Conmy
Deputy County Administrator & Economic Development Director
Sussex County
P O Box 1397
Sussex, Virginia

Dear J. David,

The Virginia Business Ready Sites Program (VBRSP) Project Review Committee and the Funding Approval Committee has recommended Sussex Mega Site to receive a VBRSP Site Development Grant FY23 of up to \$247900 to support the development efforts at the site.

Please allow four to six weeks for the processing of your draft Performance Agreement (PA). Your locality's PA will include all items specific to the needs of your site project for the completion of your efforts, including but not limited to the following: Master Planning, Wetlands Mitigation Plan, Treated Water PER, Natural Gas Feasibility and design, Stormwater Management Plan, Concept layouts, Business Models and ROI Analysis, T&E, Cultural resources, and Phase 1. You may begin spending towards the completion of your site project upon receipt of this grant award letter (GAN).

The VBRSP Team would like to offer you an opportunity for a debrief session on your site. We have set up the following times for the debrief sessions:

- Monday 1/23 2-4pm
- Wednesday 2/1 1:30-3:30pm

If you are interested, please utilize [This Link](#) to secure a time to discuss the your site with us.

Congratulations on your site's proposal! If you have any questions regarding this grant award, contact Leah P. Harrison, Grants Manager, Incentives at LHarrison@vedp.org or at (804) 213-6682. If you have any program/site implementation questions, contact John Loftus, Sites and Buildings Manager, by email at JLoftus@vedp.org or at (804) 545-5786.

Sincerely,

Leah P. Harrison
Grants Manager, Incentives Division
Virginia Economic Development Partnership
Direct: [804.545.5654](tel:804.545.5654) | Mobile: [804.213.6682](tel:804.213.6682)
VEDP.org

701 E. Franklin Street, Suite 501
Richmond, Virginia 23219

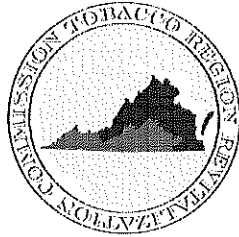

804-225-2027
www.revitalizeva.org

TOBACCO REGION REVITALIZATION COMMISSION

February 13, 2023

Mr. Richard Douglas
County Administrator
Sussex County
P.O. Box 1397
Sussex, VA 23884

RE: Grant #4111 –*Megasite - Master Planning, Conceptual Engineering, & Water Line Extension*
Current Grant Term: January 05, 2023 – January 05, 2026

Dear Mr. Douglas:

As you are aware, the Virginia Tobacco Region Revitalization Commission approved a funding request in the amount of \$61,050.00 for the project referenced above on January 05, 2023. An award package that will include a grant agreement for you to review and sign will be forthcoming, however, I write to let you know to expect additional delay.

The Commission has two types of funds from which it awards its grants: restricted and unrestricted funds. Due to the nature of your project, we have determined that it may be appropriate to use the Commission's restricted funds. The Commission's outside bond counsel is required to review all grant agreements using restricted funds prior to execution. Unfortunately, this causes additional delay.

In the meanwhile, and until we provide a grant agreement for you to execute, please consider this letter as confirmation that the Commission has awarded a grant to your organization in the amount stated above. Although we cannot process reimbursements for eligible project expenses until an executed grant agreement is in place, we will reimburse you for eligible project expenses incurred after the award date stated above.

We look forward to working with you on your project and seeing its contributions to the Tobacco Region. If you have any questions, please contact me or the Commission's Southern Regional Director, Sarah Capps at (540) 483-0179 ext. 2186 or scapps@revitalizeva.org.

Sincerely,

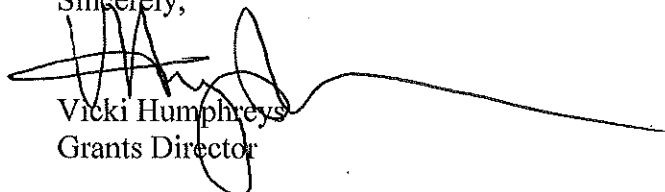

Vicki Humphreys
Grants Director

CC: Sarah Capps
David Conmy

Activity	Grant Funding Request	Funded by VBRSP?	Recommended VEDP Funding	Recommended TRRC Funding	Recommended Local Funding	Total Approved VBRSP Project Funding	Recommended Additional Local Funding
Consultant Services & Oversight for Master Planning & Conceptual Design Process	\$20,000	Yes	\$20,000			\$20,000	
Wetlands Mitigation Plan	\$25,000	Yes			\$25,000	\$25,000	
Treated Wastewater PER	\$25,000	Yes			\$25,000	\$25,000	
Natural Gas Line (Feasibility, Surveying, & Design Engineering)	\$200,000	Yes	\$200,000			\$200,000	
Stormwater Management Plan Update to Current SWM Regulations	\$25,000	Yes	\$25,000			\$25,000	
Conceptual Site Layouts with One Major User or Multiple Users	\$50,000	Yes		\$50,000		\$50,000	
Identification of Industrial Users	\$10,000	Yes		\$10,000		\$10,000	
Conceptual Rail Spur Turnouts & Internal Road Networks	\$25,000	No				\$0	\$ 25,000
Business Models & ROI Analysis for Conceptual Plan	\$10,000	Yes			\$10,000	\$10,000	
Policy Approaches to Enhance the Megasite's Competitiveness	\$5,000	Yes	\$2,900	\$1,050	\$1,050	\$5,000	
Update to Threatened & Endangered Species Study, Cultural Resources Summary, and Phase I ESA	\$10,000	No				\$0	\$ 10,000
TOTAL	\$405,000		\$247,900	\$61,050	\$61,050	\$370,000	\$35,000

required match (33%)	\$122,100.00
TRRC 50% match	\$61,050.00
Required Local Match	\$61,050.00
Total Local Funding	\$96,050.00

BOARD ACTION FORM

Agenda Item: Action Item #6.02

Subject: Fire Engine Acquisition (Stony Creek and Wakefield VFDs) – Financing Resolution

Board Meeting Date: February 23 2023

=====
Summary: A resolution is attached for your consideration that provides Board approval of additional lease purchase financing under the existing master lease agreement with Bank of America. Specifically, the resolution would begin the process of securing up to \$1,850,000 in financing for two fire engines serving the Wakefield and Stony Creek Volunteer Fire Departments, as identified in the County’s Public Safety Capital Plan. This is the same process followed for the recent acquisition of fire engines for Jarratt, Courthouse, and Waverly Volunteer Fire Departments, and an ambulance for the Stony Creek Volunteer Rescue Squad.

The Finance Committee recommended moving forward with this process at its last meeting. Roland Kooch with Davenport will be present to answer any questions regarding this process.

Recommendation: Staff recommends the Board adopts the attached resolution.

Attachments: Resolution and memo from the Public Safety Coordinator

=====
ACTION: That the Board adopts Resolutions #23-16 approving additional lease purchase financing under existing Master Lease Agreement.

MOTION BY: _____ **SECONDED BY:** _____

<u>Member</u>	<u>Aye</u>	<u>Nay</u>	<u>Member</u>	<u>Aye</u>	<u>Nay</u>
Fly	___	___	W. Jones	___	___
Futrell	___	___	Seward	___	___
D. Jones	___	___	Tyler	___	___
			White (Tie Breaker)	___	___

**RESOLUTION #23-16 OF BOARD OF SUPERVISORS OF THE
COUNTY OF SUSSEX, VIRGINIA APPROVING ADDITIONAL LEASE PURCHASE
FINANCING UNDER EXISTING MASTER LEASE AGREEMENT**

WHEREAS, the Board of Supervisors (**the “Board”**) of the County of Sussex, Virginia (**the “County”**) has determined (i) that a true and very real need exists for the acquisition, installation and equipping of various vehicles and related equipment, including, but not limited to, two pumper fire trucks by the County (**the “Equipment”**) described in the Master Lease Agreement (as hereinafter defined) and any schedules thereunder; (ii) that the Equipment is essential to the governmental functions of the County; and (iii) that it reasonably expects the Equipment to continue to be essential to the governmental functions of the County for a period not less than the term of the Master Lease Agreement; and

WHEREAS, the Board has taken the necessary steps under the Virginia Procurement Act, as amended, to acquire the Equipment; and

WHEREAS, the Board has entered into a Master Equipment Lease/Purchase Agreement dated as of April 15, 2021, including one or more schedules thereunder, in the aggregate principal amount of not to exceed \$12,200,000 (**the “Master Lease Agreement”**) with Banc of America Public Capital Corp (**the “Lessor”**) to finance the purchase of the Equipment from time to time, with each such schedule having a term not to exceed ten (10) years, such Master Lease Agreement being in accordance with the Proposal (as defined below); and

WHEREAS, the Board proposes to enter into an Equipment Schedule pursuant to the Master Lease Agreement with the Lessor in the principal amount not to exceed [\$1,850,000] (**the “Schedule No. 3”**) to finance the purchase of the Equipment over a term not to exceed ten (10) years, in accordance with the Proposal; and

WHEREAS, (i) all amounts payable by the County under the Master Lease Agreement, Schedule No. 3 and similar future schedules (**the “Lease Obligations”**) are subject to annual appropriation by the Board; (ii) the Board is not under any obligation to make any appropriation with respect to the Lease Obligations; (iii) the Lease Obligations are not a general obligation of the County or a charge against the general credit or taxing power of the County; and (iv) amounts payable by the County under the Lease Obligations do not constitute a debt of the County within the meaning of any constitutional, charter or statutory limitation; and

NOW, THEREFORE, BE IT RESOLVED, THAT:

1. The Board hereby accepts the proposal of the Lessor submitted on March 4, 2021, as updated on February __, 2023 (**the “Proposal”**) for the financing of the Equipment on the terms set forth therein, including without limitation, for Schedule No. 3, a maximum principal amount not to exceed [\$1,850,000,] a maximum annual interest rate of ___% and a maximum term of approximately ten years, and an interest rate formula for future schedules under the Master Lease Agreement as set forth in the Proposal.

2. It is hereby found and determined that the terms of the Lease Obligations as provided in the Proposal are in the best interests of the County for the design, acquisition, improvement, installation and equipping of the Equipment.

3. Schedule No. 3 and any related financing documents are hereby approved. The Chairman, the Vice Chairman and the County Administrator, each of whom is authorized to act (**each an “Authorized Official”**), and to execute, acknowledge and deliver Schedule No. 3 and related financing documents, including but not limited to an escrow agreement with an authorized escrow agent, if required, as selected by an Authorized Official and/or a restricted account agreement if utilized by the County, with any changes, insertions and omissions therein as may be approved by the Authorized Official executing Schedule No. 3 and such documents, including but not limited to the annual interest rate, payment dates, lease term, description of Equipment and prepayment provisions, such approval to be conclusively evidenced by the execution and delivery thereof. Each Authorized Official is authorized to act, and each hereby designated as authorized representatives of the County under the Master Lease Agreement and Schedule No. 3 and any escrow agreement or other related agreement until such time as the Board designates other authorized representatives. Without further authorization from the Board, (a) the aggregate principal component of Rental Payments under all schedules entered into pursuant to the Master Lease Agreement shall not exceed \$12,200,000; (b) the maximum term under any schedule entered into pursuant to the Master Lease Agreement shall not exceed ten (10) years; and (c) the maximum interest rate used to determine the interest component of rental payments under each schedule shall not exceed the lesser of the maximum rate permitted by law or five percent (5.00%) per annum. Future schedules under the Master Lease Agreement beyond the existing schedules and Schedule No. 3 require future approval by the Board.

4. The same Authorized Officials and the County Attorney are authorized and directed to execute and deliver any and all other agreements, financing statements, papers, instruments, opinions, certificates, affidavits and other documents and to do or cause to be done any and all other acts and things necessary or proper for carrying out the purposes and intents of this resolution and the Master Lease Agreement and Schedule No. 3.

5. The County covenants that it shall not take or omit to take any action the taking or omission of which will cause the Lease Obligations to be “arbitrage bonds” within the meaning of Section 148 of the Code, or otherwise cause interest on the Lease Obligations derived from the interest component of rental payments made by the County under the Master Lease Agreement to be includable in the gross income for Federal income tax purposes of the registered owners thereof under existing law. Without limiting the generality of the foregoing, the County shall comply with any provision of law that may require it at any time to rebate to the United States any part of the earnings derived from the investment of the gross proceeds of the Lease Obligations.

6. The County further covenants that it shall not permit the proceeds of the Lease Obligations to be used in any manner that would result in (a) 10% or more of such proceeds being used in a trade or business carried on by any person other than a governmental unit, as provided in Section 141(b) of the Code, provided that no more than 5% of such proceeds may be used in a trade or business unrelated to the County’s use of the Equipment, (b) 5% or more of such proceeds being used with respect to any “output facility” (other than a facility for the furnishing of water),

within the meaning of Section 141(b)(4) of the Code, or (c) 5% or more of such proceeds being used directly or indirectly to make or finance loans to any persons other than a governmental unit, as provided in Section 141(c) of the Code; provided, however, that if the County receives an opinion of nationally recognized bond counsel that any such covenants need not be complied with to prevent the interest on the Lease Obligations from being includable in the gross income for Federal income tax purposes of the registered owner thereof under existing law, the County need not comply with such covenants.

7. The Board, on behalf of the County, hereby designates the Lease Obligations as “qualified tax-exempt obligations” as defined in Section 265(b)(3)(B) of the Code and certifies by this Resolution that it does not reasonably anticipate the issuance by it or its subordinate entities of more than \$10,000,000 in “qualified tax-exempt obligations” during the calendar year 2023 and will not designate, or permit the designation by any of its subordinate entities of, any of its notes and bonds (or those of its subordinate entities) during the calendar year 2023 which would cause the \$10,000,000 limitation of Section 265(b)(3)(D) of the Code to be violated.

8. The Board intends for the Lease Obligations to be treated as complying with the provisions of Section 148(f)(4)(D) of the Code, which provides an exception from the “rebate requirement,” to the extent it complies with the provisions of Section 148(f)(4)(D)(iii) of the Code, and since (i) the Lease Obligations (1) are issued by the County which is a governmental unit with general taxing powers, (2) no bond which is a part of this issue is a private activity bond, (3) 95% or more of the net proceeds of this issue are to be used for local governmental activities entirely within the jurisdiction of the County, and (4) the aggregate face amount of all tax-exempt notes and bonds (other than private activity bonds) issued by the County during the calendar year 2023 (and notes and bonds issued by any subordinate entity of the County) is not reasonably expected to exceed \$5,000,000 except that, pursuant to the provisions of Section 148(f)(4)(D)(vii) of the Code, this amount of \$5,000,000 may increase by the lesser of \$10,000,000 or so much of the aggregate face amount of all tax-exempt bonds (other than private activity bonds) issued by the County during the calendar year 2023 (and notes and bonds issued by any subordinate entity of the County) attributable to financing the construction (within the meaning of Section 148(f)(4)(C)(iv) of the Code) of public school facilities.

9. The Board hereby determines that it is in the best interests of the County to authorize the County Treasurer to participate in the State Non-Arbitrage Program in connection with the Lease Obligations, if directed by the Chairman.

10. The recitals to this resolution are hereby incorporated by reference and are declared to be findings of the County in connection with its decision to acquire and finance the Equipment.

11. All acts of the officers, agents and representatives of the County that are in conformity with the purposes and intent of this resolution and in furtherance of the leasing of the Equipment by the County to finance the Equipment and the design, acquisition, improvement, installation and equipping of the Equipment are hereby approved, ratified and confirmed.

12. This resolution shall be effective immediately upon its adoption.

Date of Adoption: February 23, 2023.

CERTIFICATION OF ADOPTION OF RESOLUTION

The undersigned Clerk of the Board of Supervisors of the County of Sussex, Virginia hereby certifies that the Resolution set forth above was adopted during an open meeting on February 23, 2023, by the Board of Supervisors with the following votes:

Aye:

Nay:

Absent at Vote:

Abstentions:

Signed this ___ day of _____, 2023.

By: _____
Clerk, Board of Supervisors



OFFICE OF PUBLIC SAFETY

G. Reid Foster, Jr

PUBLIC SAFETY COORDINATOR

(434) 246-1305 EXT. 22

EMAIL: RFOSTER@SUSSEXCOUNTY.GOV

COUNTY OF SUSSEX, VIRGINIA

POST OFFICE BOX 1397

15080 COURTHOUSE ROAD

SUSSEX, VIRGINIA 23884

February 13, 2023

TO: RICHARD DOUGLAS

FROM: REID FOSTER

SUBJECT: NEW FIRE ENGINES

I meet with Chief Bowden and Chief Sheffield on the new engines for Wakefield and Stony Creek Fire Departments. I have enclosed copies of both proposals for the board packet. The cost of the two trucks is \$1, 700, 30.46. We are purchasing these trucks under the HGAC cooperative purchasing. I have reviewed and recommending that the Board move forward with the purchase.

If you have any questions , Please contact me.



PROPOSAL

DATE: February 9, 2023

TO THE:

Wakefield Volunteer Fire Department
155 Fleetwood Ave
Wakefield, Virginia 23888

We hereby propose and agree to furnish the following firefighting equipment upon your acceptance of this proposal:

**One (1) Sutphen Heavy Duty Pumper Complete and Delivered for the Total Sum
of\$835,846.62**

The unit shall be manufactured completely in accordance to the following proposal and delivered in approximately **42-44** months from the date of the contract signing or purchase order, subject to delays from all causes beyond our control.

This proposal shall be valid for thirty (**30**) days. If the contract or purchase order is not received within this proposed duration, we reserve the right to extend, withdraw, or modify our proposal, including pricing, delivery times, and prepayment discounts as applicable.

Respectfully submitted,

Keith Ball
Municipal Emergency Services
Authorized Representative for Sutphen
Corporation
540-797-0960



SUTPHEN CORPORATION
6450 Eiterman Road | Dublin, OH 43016 | 1-800-848-5860

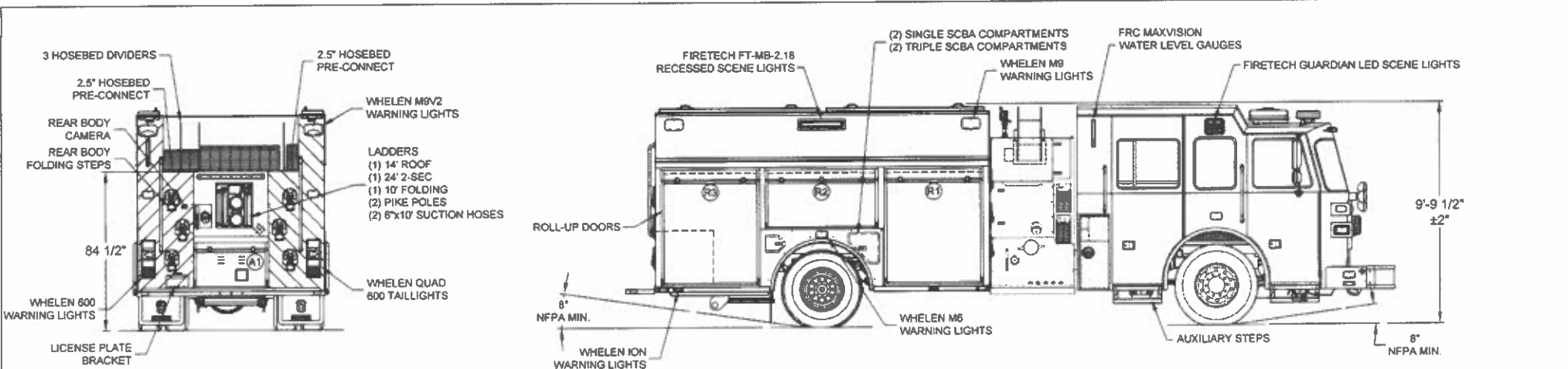

LEFT SIDE COMPARTMENTS				
COMPT	DOORS	OPENING DIMENSIONS	INSIDE DIMENSIONS	VOLUME
L1	ROLL-UP	48.75" W X 86.5" H	51.5" W X 86" H X 28"D	47.4 CU. FT. (8" X 11" D UPPER)
L2	ROLL-UP	56.25" W X 27" H	56" W X 31.5" H X 28"D	28.4 CU. FT. (8" X 11" D UPPER)
L3	ROLL-UP	48.75" W X 56.5" H	51.5" W X 56" H X 28"D	47.4 CU. FT. (8" X 11" D UPPER)
L4/L5	LIFT-UP	75" W X 9.5" H	84" W X 23" H X 13.5" D	33.8 CU. FT.

RIGHT SIDE COMPARTMENTS				
COMPT	DOORS	OPENING DIMENSIONS	INSIDE DIMENSIONS	VOLUME
R1	ROLL-UP	48.75" W X 56.5" H	51.5" W X 56" H X 28"D	47.4 CU. FT. (8" X 11" D UPPER)
R2	ROLL-UP	56.25" W X 27" H	56" W X 31.5" H X 28"D	28.4 CU. FT. (8" X 11" D UPPER)
R3	ROLL-UP	48.75" W X 56.5" H	51.5" W X 56" H X 28"D	47.4 CU. FT. (8" X 11" D UPPER)
R4/R5	LIFT-UP	75" W X 9.5" H	84" W X 23" H X 13.5" D	33.8 CU. FT.

REAR STEP COMPARTMENT				
COMPT	DOORS	OPENING DIMENSIONS	INSIDE DIMENSIONS	VOLUME
A1	ROLL-UP	36.75" W X 19" H	39.5" W X 28" H X 31"D	19.8 CU. FT.
TOTAL				333.8 CU. FT.

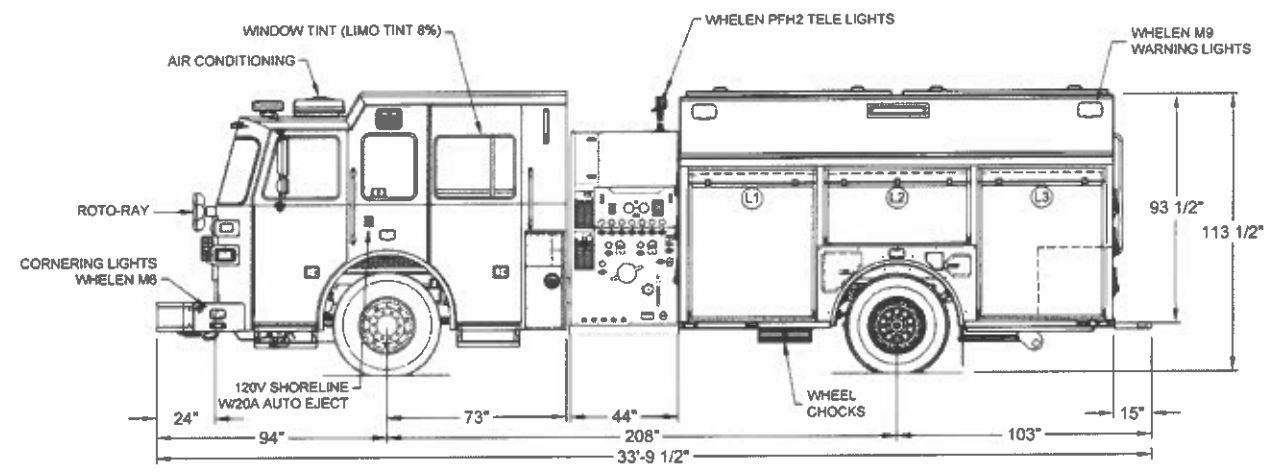
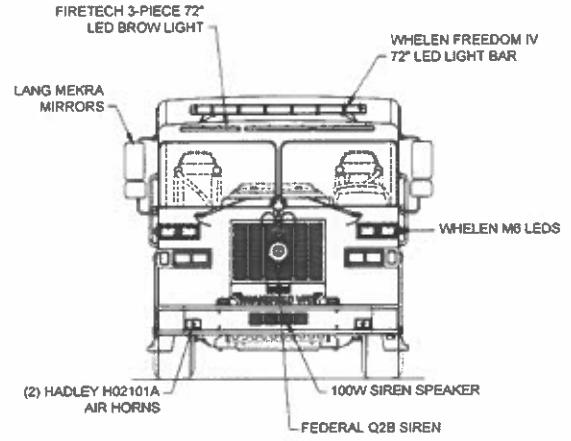
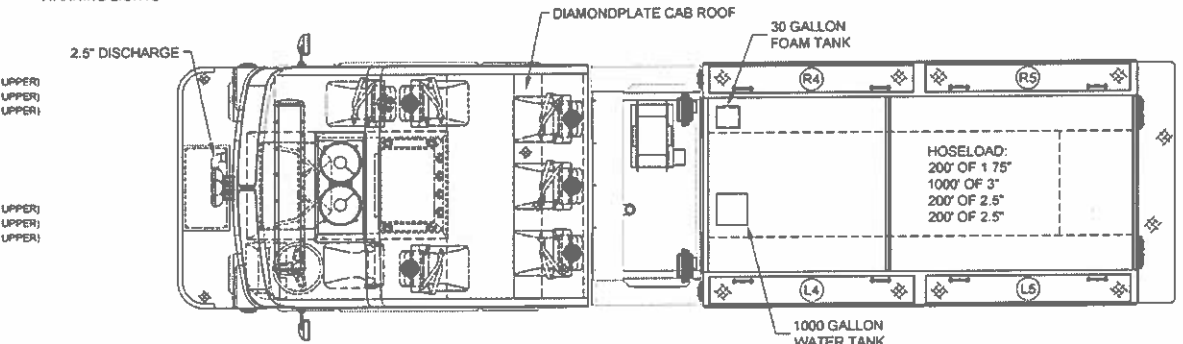

DIMENSIONS SHOWN ON THIS DRAWING ARE APPROXIMATE AND ARE SUBJECT TO MINOR DEVIATIONS DURING CONSTRUCTION. IN THE EVENT OF A DISCREPANCY BETWEEN THE SUTPHEN SPECIFICATIONS AND DRAWING, THE SUTPHEN SPECIFICATIONS SHALL PREVAIL. DRAWING IS FOR REFERENCE ONLY. SOME ITEMS PROPOSED MAY NOT BE SHOWN OR NOTED.	CUSTOMER APPROVAL		D	UPDATED DRAWING PER CUSTOMER REQUESTS	JDH	09/29/2022	Drawn by:	 SUTPHEN WAKEFIELD VOLUNTEER FIRE DEPARTMENT WAKEFIELD, VA CUSTOM PLUMBER - GBXL WAKEFIELD, VA 20222 GBXL.DWG
	NAME:		C	UPDATED DRAWING PER CUSTOMER REQUESTS	JDH	07/06/2022	J. HOWELL	
	TITLE:		B	UPDATED DRAWING PER CUSTOMER REQUESTS	JDH	07/01/2022	DATE	
	DATE:		E	UPDATED DRAWING PER CUSTOMER REQUESTS	JDH	02/07/2023	08/09/2022	
			REV.				WFC FACILITY	
				DESCRIPTION	BY	DATE	URBANA	
THIS PRINT IS PROVIDED ON A RESTRICTED BASIS AND IS NOT TO BE USED IN ANY WAY DETRIMENTAL TO THE INTEREST OF SUTPHEN CORPORATION								



Proposal for Furnishing Apparatus

Nov 1, 2022

Department: Stony Creek

Attn: [REDACTED]

12456 Hartley Street Stony Creek, Va. 23882

Upon an order being placed by you, and final acceptance by Pierce Mfg. the apparatus and equipment herein named will be manufactured for the following prices:

	Price
Pierce SABRE Pumper 152 Body Bid# 446	\$864,458.00
Pre-payment is not required but if you choose to the final price will be	(\$31,971.00)
This pricing includes Radios and installation per Sussex County Specifications	
This price includes department specified equipment and mounting	

Total: \$832,487.00

Said apparatus and equipment are to be built and shipped in accordance with the specifications hereto attached, delays due to strikes, war, or intentional conflict, failures to obtain chassis, materials, or other causes beyond our control not preventing, within about 620 calendar days after receipt of this order and the acceptance thereof by Pierce Mfg.

Taxes: Tax is not included in this proposal. In the event that the purchasing organization is not exempt from sales tax or any other applicable taxes and/or the proposed apparatus does not qualify for exempt status, it is the duty of the purchasing organization to pay any and all taxes due.

Cancellation: In the event this proposal is accepted, and a purchase order is issued then cancelled or terminated by Customer before completion, Atlantic Emergency Solutions may charge a cancellation fee of 30% of the purchase price.

Terms: The terms of this proposal will be governed by the laws of the state of Virginia. No additional terms or conditions will be binding upon Atlantic Emergency Solutions unless agreed to in writing and signed by a duly authorized officer of Atlantic Emergency Solutions.

This proposal is valid April 1 2023

Sincerely,

Randy Smith Regional Account Manager

61 Ridgeland Heights
Martinsville, Va. 24112
rsmith@atlanticemergency.com
om
276-732-0909



Sutphen
Component Report
 Dealership: Municipal Emergency
 Services

**HS- Wakefield Volunteer Fire Department,
 Virginia
 Program 1 Pumper**

Order#: DQ14818-1
 Contact: John Rose
 Position: Assistant Chief
 Phone: 757-218-5121
 Mobile:
 Email: jrosecrew@gmail.com

Quote Line Number 1

Line	Item #	Qty	Item Description/Comments
1		1	**ENG Graphics = Dealer supplied graphics will be provided for all options except rear chevrons.
2		1	**ENG Facility = Urbana Pumper Division
3		1	**ENG Truck Series = Program 1
4		1	**ENG Electrical System = Point-to-Point
5		1	**ENG Cooperative Purchasing =HGAC
6	10000225	1	STD WIRING SCHEMATIC (USB)
7	10088888	1	SPECIAL ITEM, Upgrade to G9XL Body Style
8		1	**CLAR NOTES, G9 Body with L1 and R1 widened to match L3 and R3.
9	10001220	1	MAXIMUM APPARATUS LENGTH = 420
10	10310100	1	CHASSIS
CHASSIS			
11	10010006	1	CHASSIS, CUSTOM
12		1	**ENG Modified Wheelbase
13	51070208	1	Wheelbase = 208
14	51010310	1	WHEELBASE GREATER THAN 200"
15	25010100	1	FRAME, 10" DOUBLE RAILS, SINGLE AXLE (50K PSI)
16	45010001	1	FRONT TOW EYES, BELOW BUMPER, PAINTED

Line	Item #	Qty	Item Description/Comments
17	46010000	1	REAR TOW EYES, PAINTED
18	40010250	1	STEERING - ROSS TAS-85
19	22010000	1	DRIVE LINE, SPICER, 1710 SERIES
20	23014130	1	ENGINE, CUMMINS L 9 450HP DOC-DPF-DEF-SCR OBD
21	23029100	1	ENGINE WARRANTY, 5 YEAR, 100,000 MILES FOR CUMMINS L9
22	23029300	1	AFTERTREATMENT WARRANTY, 5 YEAR, 100,000 MILES FOR CUMMINS L9
23	23030006	1	AIR INTAKE/EMBER SEPARATOR
24	23031173	1	FUEL FILTER/WATER SEPARATOR, PRIMARY, FLEETGUARD, FS1098
25	23031210	1	FUEL FILTER, SECONDARY, FLEETGUARD, FF63009
26	47012430	1	TRANSMISSION, ALLISON GEN 5, EVS3000
27	23110005	1	JACOBS ENGINE BRAKE FOR CUMMINS L ENGINES
28	47024050	1	TRANSMISSION COOLER
29	47030000	1	ALLISON TOUCH PAD SHIFTER
30		1	**ENG Shifter Pad Gearing = 5 Gears open, 6th Gear locked.
31	21021200	1	COOLING SYSTEM
32	21030195	1	COOLANT FILTER
33	21030000	1	FAN CLUTCH
34	21030200	1	RADIATOR COOLANT RECOVERY, PRESSURIZED SYST
35	26010000	1	FUEL TANK, STEEL, 65 GALLON
36	26030000	1	FUEL FILL
37	26030100	1	FUEL COOLER
38	24040000	1	DIESEL EXHAUST FLUID TANK
39		1	**ENG DEF Access = Fixed Panel, Tilt Cab for DEF Access.

Line	Item #	Qty	Item Description/Comments
40	13010205	1	ALTERNATOR, LEECE NEVILLE 320 AMP 4915PA
41	13030100	1	LOW VOLTAGE ALARM, FLOYD BELL TXB-V86-515-QF
42	15010500	1	BATTERIES, INTERSTATE TYPE 31 MHD (4)
43	15031700	1	BATTERY JUMPER TERMINALS
44	15030710	1	120V SHORELINE INLET, BLUE SEA SURE-EJECT - 20A
45		1	**ENG Shoreline Inlet Location = Driver's side of Cab, standard location.
46		1	**ENG Shoreline Cover Color = Red.
47	15040100	3	120V OUTLET WIRED TO SHORELINE INLET - EA (3)
48		1	**ENG Nema Number = 5-20 House Plug Duplex.
49		1	**ENG Outlet Locations = L1 compartment L2 compartment L3 compartment
50	15031580	1	BATTERY CHARGER, BLUE SEA PS12 W/ REMOTE BAR GRAPH DISPLAY
51		1	**ENG Battery Charger Display Location: bar graph display will be in driver's side window.
52		1	**ENG Battery Charger Note: Chassis Division to provide/install battery charger & Auto Eject (if applicable)
53	14022120	1	FRONT AXLE, HENDRICKSON STEERTEK NXT 20,000 LB.
54	41022120	1	FRONT SUSPENSION, HENDRICKSON 20,000 LBS. (4) 56" LEAFS
55	41040510	1	STEER ASSIST
56	43010305	1	FRONT TIRES, GOODYEAR 385/65R22.5 LRJ G296 22.5 x 12.25 WHEELS
57	14510530	1	REAR AXLE, MERITOR RS-26-185 27,000 LB.
58	14530100	1	TOP SPEED, 68 MPH
59	42010001	1	REAR SUSPENSION, REYCO 27,000 LBS. LEAF
60	44010320	1	REAR TIRES, GOODYEAR 12R22.5 LRH G622 MUD & SNOW 24,000 - 27,000 GVWR
61	42910300	1	TIRE PRESSURE MONITOR, QUICK PRESSURE
62	44210200	1	WHEELS, ALUM, ALCOA (max 27K rear)

Line	Item #	Qty	Item Description/Comments
63	44270100	1	HUB COVERS, FRONT & REAR, POLISHED STS (Single Axle)
64	44270300	1	CHROME LUG NUT CAPS, FRONT & REAR (Single Axle)
65	44271100	1	MUD FLAPS, FRONT (PAIR)
66	44271200	1	MUD FLAPS, REAR (PAIR)
67	54010010	1	DATA, SAFETY & WARNING TAGS APPLICATION, ADHESIVE
68	16010265	1	BRAKES STEERTEK DISC PLUS EX225 FRONT, MERITOR DISC PLUS EX225 REAR (SINGLE AXLE)
69	18010041	1	AIR BRAKE SYST 4 TANKS WABCO 1200 DRYER (24K, 27K)
70	18030140	1	AIR INLET CONNECTION
71		1	**ENG Standard Air Inlet Location = Left hand side of Driver's step well.
72	18035120	1	AIR COMPRESSOR, BLUE SEA AIR BRAKE COMPRESSOR, 125PSI
73	18220500	1	NO ELEC STABILITY CONTROL SYS
74	18110050	1	WABCO 4 CHANNEL ANTI-LOCK BRAKES W/ASR (24K, 27K)
75	53510000	1	COMPRESSION FITTINGS ON AIR SYSTEM (CHASSIS)
76	54010000	1	MISCELLANEOUS ITEMS ON CHASSIS
77	10310110	1	CAB
CAB			
78	11023250	1	CAB TSAL4E 73" 10" RR 1/2
79	11030025	1	CAB CERTIFICATION - STRUCTURAL INTEGRITY
80	11030950	1	CAB LOCKDOWN LATCHES
81	11031025	1	CAB TILT SYSTEM, AIR CONTROL VALVE
82		1	**ENG Cab Tilt Controls = Officer's side Pump Panel.
83	11031100	1	MANUAL BACK-UP TILT SYSTEM
84	11031350	1	CAB DOORS, FULL LENGTH (4)

Line	Item #	Qty	Item Description/Comments
85	11031386	1	CAB STEPS, LOWER & INTERMEDIATE DIAMONDPLATE
86	11031390	1	AUXILIARY CAB STEPS, ALUM, GRIP STRUT (SET OF 4)
87	11031399	1	CAB STEP LIGHTING, TECNIQ E45 LED STRIP LIGHTS
88	11031419	1	CAB DOOR WINDOWS, MANUAL (4)
89	11031401	1	CAB SIDE WINDOWS, FIXED, BOTH SIDES
90	11031460	1	NO WINDOWS, BACK WALL OF CAB
91	11031465	1	WINDOW TINTING (LIMO TINT 8%) - EACH (4)
92	52010010	1	ELECTRIC INTERMITTENT WIPERS
93	52030200	1	WINDSHIELD WASHER RESERVOIR
94	38010015	1	MIRRORS LANG MEKRA 300 SERIES REMOTE
95	11024400	1	UPPER GRILLE, LEVEL STYLE FACADE (L9)
96	11024510	1	FLAMING "S" LOGO, UPPER GRILLE, ILLUMINATED
97	11024615	1	LOWER GRILLE, POLISHED STAINLESS, LASER CUT LETTERING W/ BACKLIGHTING
98		1	**ENG Design for lower grille w/LED backlight = Text = Wakefield VFD LED Color = Red. (Note: Text cannot be larger than air cut-outs.)
99	20010085	1	BUMPER, 24" POLISHED STAINLESS STEEL
100	20029800	1	BUMPER SIDES, DIAMONDPLATE
101	20040200	1	STORAGE WELL, CENTER ONLY (24" BUMPER)
102	20040295	1	SPECIAL Storage Well Cover Flush Storage well cover
103		1	**CLAR NOTES, Storage well cover shall be flush with the diamond plate on the front bumper.
104	20030500	1	NO CUT-OUT IN STORAGE WELL COVER
105	12010410	1	AIR HORNS, DUAL, HADLEY H02101A RECTANGULAR, THRU BUMPER
106		1	**ENG Air Horns Location: Outboard, (1) each side.
107	12030305	1	FOOT SWITCH, DRIVER'S SIDE

Line	Item #	Qty	Item Description/Comments
108	12030310	1	FOOT SWITCH, OFFICER'S SIDE
109	12510420	1	ELEC SIREN, POWERCALL UDX7
110	12530205	1	ELEC SIREN WIRED TO STEERING WHEEL BUTTON
111	12620100	1	SIREN SPEAKER, 100W, CAST PRODUCTS, SA4201-6B-A
112	12670120	1	SIREN SPEAKER(S) INSTALLED IN BUMPER BEHIND PERFORATIONS
113	12710100	1	SIREN, FEDERAL Q2B, GRILLE MOUNT
114		1	**ENG Q2B Wiring = Wired to Emergency Master then shed with parking brake on.
115	12730305	1	FOOT SWITCH, DRIVER'S SIDE, FOR MECH SIREN
116	12730310	1	FOOT SWITCH, OFFICER'S SIDE, FOR MECH SIREN
117	12730363	1	SIREN BRAKE SWITCH FOR MECH SIREN, DRIVER'S & OFFICER'S SIDE
118		1	**ENG Located in Lower Console Position 2
119		1	**ENG Located in Lower Console Position 5
120	32520520	1	HEADLIGHTS, LED, FIRETECH FT-4X6, DUAL STS HOUSINGS
121		1	**ENG Headlight Interior Finish = Chrome.
122	48010300	1	FRONT TURN SIGNALS, WHELEN 400 SERIES LED (4)
123	32530630	1	CORNERING LIGHTS, WHELEN M6 LED
124	32530754	1	ICC, LED BROW LIGHT INTEGRATED MARKERS
125	27022155	1	HANDRAILS, CAB EXTERIOR, HANSEN BACKLIT (4) SIDE
126		1	**ENG Cab Exterior Handrails Backlighting Color = White.
127	27025000	1	HANDRAILS, CAB INTERIOR, BLACK RUBBER COATED (2) FRONT ENTRY
128	27030120	1	HANDRAILS, REAR CAB INTERIOR DOOR, BLACK RUBBERIZED (2) AND KNURLED STS AT WINDOW (2)
129	27040100	1	INTERIOR DOOR, NYLON STRAP
130	11032010	1	EXTERIOR COMPT, SIDE OF EXT CAB, 38" H, DS

Line	Item #	Qty	Item Description/Comments
131	11032410	1	EXTERIOR COMPARTMENT DOOR LOCK
132	11032110	1	OPENING TO DRIVER'S SIDE CREW SEAT COMPT
133	11032060	1	EXTERIOR COMPT, SIDE OF EXT CAB, 38" H, OS
134	11032410	1	EXTERIOR COMPARTMENT DOOR LOCK
135	11032120	1	OPENING TO OFFICER'S SIDE CREW SEAT COMPT
136	11032300	1	PIKE POLE STORAGE, EXTERIOR CAB COMPT
137	11032332	1	FMI DOUBLE FIRE EXTINGUISHER TILT OUT BRACKET, EXTERIOR CAB COMPT (1)
138		1	**ENG Location of Accessories in Ext Cab Compt = (2) Pike pole shall be mounted to the inside rear of the exterior compartment. Pike poles shall be accessible from the officers side exterior compartment Fire extinguisher holders shall be located in the officers side exterior compartment.
139	11035400	1	DIAMONDPLATE REAR EXTERIOR WALL OF CAB
140	11035420	1	DIAMONDPLATE CAB ROOF 30" x FULL WIDTH
141	31010287	1	INTERIOR, MULTISPEC GRAY SPECKLE PAINT W/GRAY-BLACK DURAWEAR
142	11032929	1	DOOR PANEL, FULL STS
143	31010290	1	CAB INTERIOR FLOOR COVERING, GRAY RUBBERIZED
144	22510100	1	ENGINE ENCLOSURE, FULL LENGTH
145	22510531	1	ENGINE ENCLOSURE COVERING, SCORPION GRAY URETHANE BLEND
146	11031677	1	CENTER CONSOLE NOT PROVIDED
147	22610000	1	ENGINE HOOD LIGHT, HALOGEN (1)
148	11031510	1	FLAT WORK SURFACE IN LIEU OF GLOVE BOX
149	11031710	1	UPPER CREW DOOR AREA, SMOOTH PANEL
150	29810100	1	CHASSIS ELECTRICAL DESCRIPTION
151	30010130	1	INSTRUMENTATION, AMETEK W/ CENTER & OVERHEAD CONSOLES

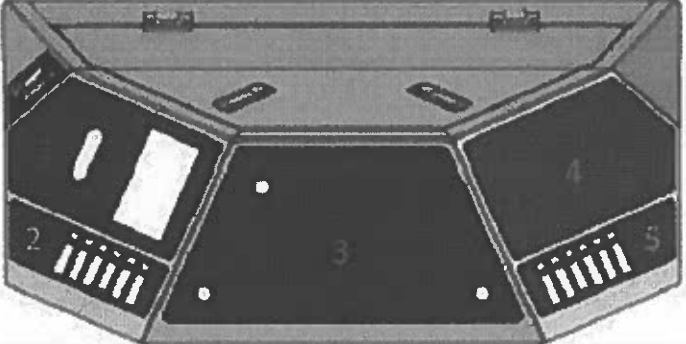
Line	Item #	Qty	Item Description/Comments
			<p>Upper Command Console:</p> 
152		1	**ENG Overhead Console Panel's Finish: Black Wrinkle.
153	30010500	1	LOWER COMMAND CONSOLE, L9 & X12
			<p>Lower Command Console (9L & 12L engines):</p> 
154		1	**ENG Lower Command Console Finish: Gray Urethane.
155		1	**ENG Lower Console Panel's Finish: Black Wrinkle.
156	30010710	1	CAB PUMP SHIFTER, AIR (FOR HALE G-SERIES / WATEROUS C20 PUMP TRANSMISSION)
157	30011000	1	PUMP INTERLOCK, NOT CONNECTED WITH ODOMETER
158	30031610	1	DO NOT MOVE LIGHT, WHELEN TIR3 LED
159		1	**ENG Door Ajar Light Location = Centered below upper command console.
160	30031650	1	DO NOT MOVE ALARM
161	29930200	1	MAPBOOK SLOT ON BREAKER PANEL
162	29910100	1	PROGRAMMABLE LOAD MANAGER, CLASS-1 SUPERNODE II
163	30031100	1	HIGH IDLE SWITCH
164	30031775	1	12V POWER POINTS, (2)

Line	Item #	Qty	Item Description/Comments
165		1	**ENG Power Point Location #1: Lower Console Position 3, Driver's corner.
166		1	**ENG Power Point Location #2: Lower Console Position 3, Officer's corner.
167	30031802	1	12V DUAL PORT USB POWER POINTS, (2)
168		1	**ENG USB Power Point Location #1: Lower Console Position 3, Driver's corner.
169		1	**ENG USB Power Point Location #2: Lower Console Position 3, Officer's corner.
170	11040000	1	CAB ACCESSORY FUSE PANEL
171	84541540	1	POWER & GROUND STUDS, UPPER COMMAND CONSOLE
172		1	**ENG Requirements (AMPS) for Power/Ground Studs in Upper Command Console: (1) 12-volt 60-amp, direct to the battery ignition off. (1) 12-volt 30-amp switched battery first position on ignition switch. (1) 12-volt 30-amp ignition power second position on ignition switch. (1) 12-volt 125-amp ground.
173	84541545	1	POWER & GROUND STUDS, LOWER COMMAND CONSOLE
174		1	**ENG Requirements (AMPS) for Power/Ground Studs in Lower Command Console: (1) 12-volt 60-amp, direct to the battery. (1) 12-volt 30-amp controlled by the ignition switch. (1) 12-volt 125-amp ground.
175	30110000	1	VEHICLE DATA RECORDER, AKRON/WELDON
176	33510030	1	INTERIOR CAB LIGHTS, WHELEN 6" ROUND RED/CLEAR LED (2)
177	34010030	1	INTERIOR CREW LIGHTS, WHELEN 6" ROUND RED/CLEAR LED (2)
178	28010750	1	DEFROSTER, HEATER & A/C, SEVERE CLIMATE (TM-31)
179	28090003	1	HEAT TO FEET
180	28030500	1	DEFROSTER DUCTWORK, ENTIRE WINDSHIELD
181	11031687	1	TOP HEAT/AC STORAGE, TOOL MOUNTING PLATE, 25" x 19.5"
182	38510105	1	DRIVER'S SEAT, BOSTROM SIERRA HIGH BACK AIR RIDE ABTS (DURAWEAR)
183	38320000	1	HELMET STORED IN COMPARTMENT
184	39090000	1	OFFICER'S SEAT, BOSTROM TANKER 350, ABTS SCBA (DURAWEAR)
185	39030010	1	OFFICER'S SEAT COMPT, OPEN FRONT
186	38320000	1	HELMET STORED IN COMPARTMENT

Line	Item #	Qty	Item Description/Comments
187	39521105	1	CREW SEAT 1, BOSTROM TANKER 350, ABTS SCBA (DURAWEAR)
188	38320000	1	HELMET STORED IN COMPARTMENT
189	39521106	1	CREW SEAT 2, BOSTROM TANKER 350, ABTS SCBA (DURAWEAR)
190	38320000	1	HELMET STORED IN COMPARTMENT
191	39521450	1	CREW SEAT 3, BOSTROM TANKER 350, ABTS SCBA FIXED (DURAWEAR)
192	38320000	1	HELMET STORED IN COMPARTMENT
193	39521451	1	CREW SEAT 4, BOSTROM TANKER 350, ABTS SCBA FIXED (DURAWEAR)
194	38320000	1	HELMET STORED IN COMPARTMENT
195	39521452	1	CREW SEAT 5, BOSTROM TANKER 350, ABTS SCBA FIXED (DURAWEAR)
196	38320000	1	HELMET STORED IN COMPARTMENT
197		1	**CLAR NOTES, Crew seats 3,4,5 shall be spaced out roughly 5 inches from each other.
198	39550100	1	SEAT COLOR, GRAY
199	39610000	6	SCBA BRACKETS, BOSTROM, SECURE ALL (6)
200	38410000	1	SEAT BELT WARNING SYSTEM, AKRON / WELDON
201	39710018	1	CREW SEAT COMPT, OPEN FRONT, W/WEBBING (73" CAB)
202	39588888	1	SPECIAL ITEM, UPGRADE TO DURAWEAR RED SEAT COLOR
203		1	**CLAR NOTES, All seats shall be covered in Durawear Red colored material
204	84541601	1	MOUNTING OF CUSTOMERS RADIO-DUAL HEAD
205		1	**ENG Radio Make & Model = Motorola APX 8500
206		1	**ENG Radio Head Mounting Location = Overhead Command Console Position 6.
207		1	**ENG Radio Unit Mounting Location = Overhead Command Console.
208	84541700	2	INSTALLATION OF CUSTOMERS 2-WAY RADIO ANTENNA (2)
209		1	**ENG Antenna Termination Location #1 = TBD @ Precon.

Line	Item #	Qty	Item Description/Comments
210		1	**ENG Antenna Termination Location #2 = TBD @ Precon.
211	30080150	1	HD STEREO, JENSEN, AM/FM/WB/BT
212	84561010	1	CAMERA SYSTEM, FRC, INVIEW TRUEVIEW, SINGLE CAMERA (WIRED)
213		1	**ENG Camera Mounting Location Rear of Body.
214		1	**ENG Camera Monitor Mounting Location Overhead Command Console Position 2.
215	11088888	1	SPECIAL ITEM, PUMP PANEL CAMERA SYSTEM, FRC, INVIEW TRUEVIEW, SINGLE CAMERA (WIRED)
216		1	**CLAR NOTES, A camera shall be mounted on the officer side pump panel to allow the driver/operator a view of the fire ground without having to leave the pump panel. A second camera monitor shall be installed on the drivers side pump panel to allow driver/operator to view what the officers side pump panel is looking at.
217	10310200	1	PUMP & PLUMBING
PUMP & PLUMBING			
218	60089905	1	PUMP, WATEROUS S101 1500GPM, SINGLE STAGE
219	60025300	1	GEARBOX, WATEROUS, REAR MOUNTED
220	60025950	1	PUMP GEARBOX YOKE, 1710
221	60026032	1	MECHANICAL PUMP SEAL, WATEROUS (PRG)
222	60030370	1	MANUAL PUMP OVERRIDE (PRG)
223	60031001	1	ZINC ANODES, WATEROUS (2)
224	60035123	1	PUMP TEST, THIRD PARTY TESTING
225	61510000	1	AUXILIARY COOLER (HEAT EXCHANGER)
226	62010002	1	STAINLESS STEEL PIPING
227	66090010	1	3" TANK-TO-PUMP W/CHECK VALVE
228	61729121	1	VALVE, AKRON, HEAVY DUTY
229	61770902	1	ACTUATOR, VALVE, PUSH/PULL, INNOVATIVE CONTROLS
230	73090001	1	TANK FILL 2"

Line	Item #	Qty	Item Description/Comments
231	61729121	1	VALVE, AKRON, HEAVY DUTY
232	61770902	1	ACTUATOR, VALVE, PUSH/PULL, INNOVATIVE CONTROLS
233	61090009	1	PRESSURE GOVERNOR, FIRE RESEARCH, PUMP BOSS
234	61290020	1	INTAKE PRESSURE CONTROL, TFT A1860
235	63021500	1	6" MAIN SUCTION, LEFT SIDE
236	65090000	1	2.5" LEFT SIDE INLET
237	61729121	1	VALVE, AKRON, HEAVY DUTY
238	61770905	1	ACTUATOR, VALVE, SWING CONTROL
239	60036020	1	THREADS, SPECIAL
240	63034750	1	ADAPTER, 2.5" NST M X 2.5" SPEC FE SWIVEL, W/PLUG & CHAIN
241	63025500	1	6" MAIN SUCTION, RIGHT SIDE
242	64090000	1	2.5" RIGHT SIDE INLET
243	61729121	1	VALVE, AKRON, HEAVY DUTY
244	61770905	1	ACTUATOR, VALVE, SWING CONTROL
245	60036020	1	THREADS, SPECIAL
246	63034750	1	ADAPTER, 2.5" NST M X 2.5" SPEC FE SWIVEL, W/PLUG & CHAIN
247	70525900	1	2.5" DISCHARGE, LEFT - POSITION 1
248	61729121	1	VALVE, AKRON, HEAVY DUTY
249	61770902	1	ACTUATOR, VALVE, PUSH/PULL, INNOVATIVE CONTROLS
250	77090015	1	GAUGE, DISCH, INNOVATIVE CONTROLS TC SERIES, 2.5"
251	61810150	1	DISCHARGE TERMINATION, 30 DEGREE ELBOW
252	60036020	1	THREADS, SPECIAL
253	61850100	1	ADAPTER, 2.5" NST FM X 2.5" SPEC M W/CAP & CHAIN

Line	Item #	Qty	Item Description/Comments
254	70525900	1	2.5" DISCHARGE, LEFT - POSITION 2
255	61729121	1	VALVE, AKRON, HEAVY DUTY
256	61770902	1	ACTUATOR, VALVE, PUSH/PULL, INNOVATIVE CONTROLS
257	77090015	1	GAUGE, DISCH, INNOVATIVE CONTROLS TC SERIES, 2.5"
258	61810150	1	DISCHARGE TERMINATION, 30 DEGREE ELBOW
259	60036020	1	THREADS, SPECIAL
260	61850100	1	ADAPTER, 2.5" NST FM X 2.5" SPEC M W/CAP & CHAIN
261	71025900	1	2.5" DISCHARGE, RIGHT - POSITION 3
262	61729121	1	VALVE, AKRON, HEAVY DUTY
263	61770902	1	ACTUATOR, VALVE, PUSH/PULL, INNOVATIVE CONTROLS
264	77090015	1	GAUGE, DISCH, INNOVATIVE CONTROLS TC SERIES, 2.5"
265	61810150	1	DISCHARGE TERMINATION, 30 DEGREE ELBOW
266	60036020	1	THREADS, SPECIAL
267	61850100	1	ADAPTER, 2.5" NST FM X 2.5" SPEC M W/CAP & CHAIN
268	71990000	1	DISCHARGE 2.5" FRONT/LEFT OF MAIN HOSEBED
269	61729121	1	VALVE, AKRON, HEAVY DUTY
270	61770902	1	ACTUATOR, VALVE, PUSH/PULL, INNOVATIVE CONTROLS
271	77090015	1	GAUGE, DISCH, INNOVATIVE CONTROLS TC SERIES, 2.5"
272	61810160	1	DISCHARGE TERMINATION, STRAIGHT
273	60036020	1	THREADS, SPECIAL
274	61850100	1	ADAPTER, 2.5" NST FM X 2.5" SPEC M W/CAP & CHAIN
275	72090000	1	DISCHARGE 2.5" FRONT/RIGHT OF MAIN HOSEBED
276	61729121	1	VALVE, AKRON, HEAVY DUTY

Line	Item #	Qty	Item Description/Comments
277	61770902	1	ACTUATOR, VALVE, PUSH/PULL, INNOVATIVE CONTROLS
278	77090015	1	GAUGE, DISCH, INNOVATIVE CONTROLS TC SERIES, 2.5"
279	61810160	1	DISCHARGE TERMINATION, STRAIGHT
280	60036010	1	THREADS, NST
281	72280010	1	2.5" FRONT BUMPER DISCHARGE, 2.5" PLUMBING
282	61729121	1	VALVE, AKRON, HEAVY DUTY
283	61770902	1	ACTUATOR, VALVE, PUSH/PULL, INNOVATIVE CONTROLS
284	77090015	1	GAUGE, DISCH, INNOVATIVE CONTROLS TC SERIES, 2.5"
285	60036010	1	THREADS, NST
286	61840100	1	ADAPTER, 2.5"NST FE X 1.5" NST M W/CAP & CHAIN
287		1	**ENG Front Bumper Swivel Location/Side = Officer's side.
288		1	**ENG Front Discharge Swivel Location/Trough = In Trough.
289	72590002	1	DECK GUN DISCHARGE 3"
290	61729161	1	VALVE, AKRON, SLOW CLOSE
291	61770902	1	ACTUATOR, VALVE, PUSH/PULL, INNOVATIVE CONTROLS
292	77090015	1	GAUGE, DISCH, INNOVATIVE CONTROLS TC SERIES, 2.5"
293	72570110	1	DECK GUN TERMINATION, FLANGED
294	72555845	1	MONITOR, TFT XFC-42 CROSSFIRE W/SAFETY FLOW W/QUAD STACK TIPS & STREAM SHAPER
295		1	**ENG Ground Base Inlet size = (2) 2.5" NST Inlets
296	72570200	1	EXTEND-A-GUN, TASK FORCE TIPS XG18, MANUAL
297	72588888	1	SPECIAL ITEM, BALL VALVE
298		1	**CLAR NOTES, A flanged ball valve at the termination before the monitor.
299	60036020	1	Special Threads = 2.9375X7

Line	Item #	Qty	Item Description/Comments
300	72890005	1	CROSSLAY, ONE 2.5" & SPEEDLAYS, TWO 2" W/SWIVELS & POLY LIFT-OUT TRAYS
301		1	**ENG Crosslay Hose Load Requirement = (2) 200 foot 1.75 pre-connected (1) Compartment in placed of 2.5 discharge.
302	61729121	3	VALVE, AKRON, HEAVY DUTY (3)
303	61770902	3	ACTUATOR, VALVE, PUSH/PULL, INNOVATIVE CONTROLS (3)
304	77090015	3	GAUGE, DISCH, INNOVATIVE CONTROLS TC SERIES, 2.5" (3)
305	60036010	3	THREADS, NST (3)
306	72910807	1	COVERS, ALUM/WEBBING FOR CROSSLAY/SPEEDLAY
307		1	**ENG Crosslay/Speedlay Side Covers Color = Black.
308	72932230	1	COVER FASTENERS, METAL AIRPLANE LATCHES
309		1	**ENG Specify details for side covers: Number of flaps, fasteners & and how they terminate (manufacturer's discretion or customer specified?) = TBD @ Pre-Con.
310	72888888	1	SPECIAL ITEM, Compartment for 2.5 discharge
311		1	**CLAR NOTES, A compartment shall be installed on the pump panel in place of the 2.5 discharge. Compartment shall have no plumbing at all installed. Compartment shall have push button latch and shall be covered in the same material that is call out for on the pump panel. Compartment shall have (1) poly slide out hose tray installed
312	84090003	1	BOOSTER REEL, LOW PRESSURE, W/150' OF 1" HOSE & NOZZLE, MTD IN DUNNAGE AREA (SM)
313	61729121	1	VALVE, AKRON, HEAVY DUTY
314	61770932	1	ACTUATOR, VALVE, AIR, W/ TOGGLE SWITCH
315	60036010	1	THREADS, NST
316		1	**ENG Booster Reel Nozzle = Akron1702
317	61742000	1	MASTER PUMP DRAIN, MULTIPOINT
318	61790500	12	DRAIN VALVES, INNOVATIVE CONTROLS, LIFT-UP (12)
319	10310210	1	FOAM SYSTEM
FOAM SYSTEM			
320	73590630	1	FOAM SYSTEM, WATEROUS AQUIS 3.0 (PRG)

Line	Item #	Qty	Item Description/Comments
321		1	**ENG Class of Foam = Class B Foam
322	73531425	1	FOAM TANK 30 GALLON BUILT INTO BOOSTER TANK
323	10310220	1	PUMP PANEL
PUMP PANEL			
324	74914130	1	PRG SM3 - SIDE MOUNT PUMP PANEL (CROSSLAY/SPEEDLAYS)
325	74928100	1	PUMP MODULE LENGTH, 44"
326	74929230	1	WATEROUS PUMP MODULE CONFIGURATION, SIDE MOUNT, CROSSLAY W/SPEEDLAYS
327	74930710	1	PANEL FINISH, BRUSHED STS 14 GAUGE (PRG)
328		1	**ENG Pump Panel Label Verbiage Standard = Yes.
329	74931055	1	COLOR CODING (PRG)
330		1	**ENG Color Coding Standard = Yes.
331	74931290	1	PUMP MODULE FRAMEWORK, SWIRL FINISH
332	74931390	1	PUMP FINISH, PAINTED BY PUMP MFG
333	74931590	1	PLUMBING FINISH, NON-PAINTED
334		1	**ENG Non-Painted Plumbing = Stainless steel welds shall be treated/coated.
335	74931690	1	EXTERIOR DUNNAGE AREA PANEL, BRUSHED STS
336	75590010	1	PUMP OPERATOR LIGHTS, LED (PRG)
337	75590110	1	PUMP PANEL LIGHTS OFFICER'S SIDE, LED (PRG)
338	76090002	1	PUMP PANEL GAUGES & CONTROLS (PRG)
339	60090040	1	PUMP PRIMER, TRIDENT, AIR
340	76025110	1	COMPRESSION FITTINGS ON AIR SYSTEM (PRG PUMP MODULE)
341	76031900	1	AIR HORN PUSH BUTTON SWITCH ON PUMP PANEL
342	76590015	1	GAUGES, MASTER, INNOVATIVE CONTROLS TC SERIES , 4" (PRG)

Line	Item #	Qty	Item Description/Comments
343	77590005	1	GAUGE, WATER LEVEL, FIRE RESEARCH, TANKVISION PRO400
344	77532230	1	GAUGE, WATER LEVEL, FRC MAXVISION REMOTE (3)
345		1	**ENG FRC MaxVision Gauge Location 1 = Driver's side of Cab, behind Crew Door, high.
346		1	**ENG FRC MaxVision Gauge Location 2 = Officer's side of Cab, behind Crew Door, high.
347		1	**ENG FRC MaxVision Gauge Location 3 = Rear of Body, Driver's side.
348		1	**ENG Whelen FR MaxVision Water Level Gauge Color Multi Color.
349	77590041	1	GAUGE, FOAM LEVEL, FIRE RESEARCH TANKVISION PRO400
350		1	**ENG Class of Foam for Foam Gauge = Class B.
351	10310230	1	WATER TANK
WATER TANK			
352	83525200	1	WATER TANK BRAND, UPF
353	83590005	1	WATER TANK, 1000 GAL, POLY
354	73030300	1	DIRECT TANK FILL 2.5" REAR
355	61729121	1	VALVE, AKRON, HEAVY DUTY
356	61770905	1	ACTUATOR, VALVE, SWING CONTROL
357	10310300	1	BODY
BODY			
358	80089500	1	BODY SUBFRAME, PROGRAM 1 PUMPER
359	80189590	1	BODY G9 - ALUM 40/51 LADDERS THRU TANK
360	80245012	1	UPPER HATCH COMPARTMENT, LEFT & RIGHT SIDES
361	10310302	1	BODY COMPARTMENTS
BODY COMPARTMENTS			

Line	Item #	Qty	Item Description/Comments
			<p style="text-align: center;">Standard Verbiage for locations of Outlets and other components in Body compartments</p> <div style="display: flex; justify-content: space-around;"> <div style="text-align: center;"> <p>TOP VIEW</p> </div> <div style="border: 1px solid black; padding: 5px;"> <p style="text-align: center;">Legend</p> <p>Inboard— Toward center of truck / frame rails</p> <p>Outboard— Toward compartment doors</p> <p>Left/Right wall— Looking at compartment, wall which is to your left or right</p> </div> </div> <div style="text-align: center; margin-top: 10px;"> <p>SIDE VIEW</p> </div>
362	81130200	1	ADJUSTABLE SHELF [L1] (1)
363	81150100	1	250# ROLL OUT DRAWER ADJUSTABLE TRACK [L1] (1)
364	81150200	1	250# SLIDE-MASTER SLIDE OUT/TILT DOWN DRAWER [L1] (1)
365	80250100	3	TURTLE TILE ON COMPT FLOOR, SHELF, TRAY OR DRAWER [L1] (3)
366	81150200	1	250# SLIDE-MASTER SLIDE OUT/TILT DOWN DRAWER [L2] (1)
367	80250100	1	TURTLE TILE ON COMPT FLOOR, SHELF, TRAY OR DRAWER [L2] (1)
368	81130200	4	ADJUSTABLE SHELF [L3] (4)
369	81140100	1	FIXED VERTICAL DIVIDER [L3] (1)
370	81150000	2	250# ADJUSTABLE VERTICAL SLIDE-OUT PANEL [L3] (2)
371	81150100	1	250# ROLL OUT DRAWER ADJUSTABLE TRACK [L3] (1)
372	80250100	8	TURTLE TILE ON COMPT FLOOR, SHELF, TRAY OR DRAWER [L3] (8)
373	81130200	1	ADJUSTABLE SHELF [R1] (1)
374	81150100	1	250# ROLL OUT DRAWER ADJUSTABLE TRACK [R1] (1)
375	81150200	1	250# SLIDE-MASTER SLIDE OUT/TILT DOWN DRAWER [R1] (1)

Line	Item #	Qty	Item Description/Comments
376	80250100	3	TURTLE TILE ON COMPT FLOOR, SHELF, TRAY OR DRAWER [R1] (3)
377	81150050	1	250# ADJUSTABLE SWING-OUT TOOL BOARD [R2] (1)
378	80250100	1	TURTLE TILE ON COMPT FLOOR, SHELF, TRAY OR DRAWER [R2] (1)
379	80280410	1	3/16" ALUMINUM MOUNTING PLATE (PER WALL) [R2] (1)
380	81130200	1	ADJUSTABLE SHELF [R3] (1)
381	81140100	1	FIXED VERTICAL DIVIDER [R3] (1)
382	81150100	1	250# ROLL OUT DRAWER ADJUSTABLE TRACK [R3] (1)
383	81150200	1	250# SLIDE-MASTER SLIDE OUT/TILT DOWN DRAWER [R3] (1)
384	80250100	3	TURTLE TILE ON COMPT FLOOR, SHELF, TRAY OR DRAWER [R3] (3)
385	81150100	1	250# ROLL OUT DRAWER ADJUSTABLE TRACK [A1] (1)
386	80250100	1	TURTLE TILE ON COMPT FLOOR, SHELF, TRAY OR DRAWER [A1] (1)
387		1	**ENG Turtle Tile Color = Red
388	81165705	1	UNISTRUT TRACK IN COMPTS
389	80290026	1	COMPT DOORS, AMDOR ROLL-UP, PAINTED
390	80230600	1	DOOR SILL PROTECTION, BODY COMPTS, PROTEC, CLEAR FILM
391	80225100	1	REAR COMPT DOOR (A1) AMDOR ROLL-UP, SATIN FINISH
392	80230660	1	DOOR SILL PROTECTION, REAR COMPT, PROTEC, CLEAR FILM
393	80230003	6	ROLL-UP DOOR DRIP PAN/GUARD (WITH DRAIN) (6)
394	80230300	1	COMPT INTERIOR FINISH, SMOOTH
395	84531215	1	COMPT LIGHTING, TECNIQ LED E44 LIGHT STRIPS, 2 PER COMPT
396	10310305	1	BODY EXTERIOR
BODY EXTERIOR			
397	81380000	1	HOSEBED W/REMOVABLE ALUMINUM FLOORING

Line	Item #	Qty	Item Description/Comments
398		1	**ENG List the Hose Bed Hose Load Req. = 200ft of preconnected 2.5 200ft of 2.5 dead loaded 1000ft of 3 200ft of preconnected 1.75
399	81330100	1	STANDARD HOSEBED HEIGHT
400	81410000	1	COVER, VINYL, MAIN HOSE BED
401		1	**ENG Hosebed Cover Color = Red.
402	81440230	1	COVER FASTENERS, METAL AIRPLANE LATCHES
403		1	**ENG Specify number of rear flaps, fasteners & and how they terminate (manufacturer's discretion or customer specified?) = TBD @ Pre-Con.
404	81330303	1	HOSE BED DIVIDERS, ADJ (3)
405	81332015	1	HOSEBED LIGHTING, FRONT, TECNIQ E44 LED LIGHT STRIP
406	81910100	1	HANDRAILS, KNURLED STS
407	82290010	1	STEPS, FRONT BODY, IC FOLD DOWN W/LIGHT
408		1	**ENG Step Light Color = White.
409	82390005	1	STEPS, REAR BODY (IC FOLD DOWN W/LIGHT)
410	82510000	1	RUB RAILS, ANODIZED ALUM
411	83010050	1	ALUMINUM TREADPLATE (ALUM PPR, PRG1, C-SER, TANKER)
412	83030355	1	REAR STEP/TAILBOARD CORNERS, STRAIGHT (PRG1)
413	80290051	1	8 SCBA CYLINDER COMPTS (2 TRIPLE-FMI, 2 SINGLES-SIG4)
414		1	**ENG Triple Bottle Compartment Location = Triple bottle compartments shall be installed drivers side front and officers side front
415	80290220	1	DIVIDER FOR (2) TRIPLE SCBA COMPARTMENTS
416		1	**ENG Location of Dividers for Triple SCBA Compartments = TBD@Precon
417	80290310	2	DOOR FINISH, BRUSHED STAINLESS, SINGLE/DOUBLE SCBA COMPT (2)
418	80290420	2	DOOR FINISH, BRUSHED STAINLESS, TRIPLE SCBA COMPT (2)
419	88520100	1	SUCTION HOSE, (2) 10' SECT 6" KOCHER LIGHTWEIGHT

Line	Item #	Qty	Item Description/Comments
420	88540350	1	SUCTION HOSE MOUNTED IN LADDER CHUTE
421	88550100	1	STRAINER, 6" KOCHER BARREL
422	89988888	1	SPECIAL ITEM, Body to Match Cab Height
423		1	**CLAR NOTES, The body shall be matched to the overall height of the cab.
424	83030710	1	REAR FENDERS, ALUMINUM SMOOTH PAINTED
425	89010000	1	DUO-SAFETY 900A 24'2-SEC & 775A 14' ROOF & 10' FOLDING
426	89590007	1	LADDER CHUTE W/SUCTION HOSE STORAGE & PIKE POLE STORAGE
427	89520210	1	LADDER ENCLOSURE, DIAMONDPLATE DOOR
428	10310310	1	ELECTRICAL
ELECTRICAL			
429	84550110	1	LICENSE PLATE BRACKET W/ LIGHT, LED
430	84511100	1	BODY ELECTRICAL DESCRIPTION
431	84520000	1	BACK UP ALARM, ECCO SA917
432	85010302	1	TAILLIGHTS, WHELEN 600 SERIES, LED STOP/TAIL/TURN/REVERSE, QUAD HOUSING (PAIR)
433		1	**ENG Tail Light Housing Color = Chrome.
434	85110100	1	ICC LIGHTS, LED
435	85510200	1	STEP LIGHTS, LED, REAR BODY & WHELEN 2G AT PUMP PANEL
436	85710030	1	UNDERCARRIAGE GROUND LIGHTS, TECNIQ E10 LED
437	86528999	1	DELETE REAR WORK LIGHTS
438	86590888	1	~UPGRADE SCENELIGHTS
439	86600000	1	OPTICAL WARNING SYSTEM, UPPER (PUMPER)

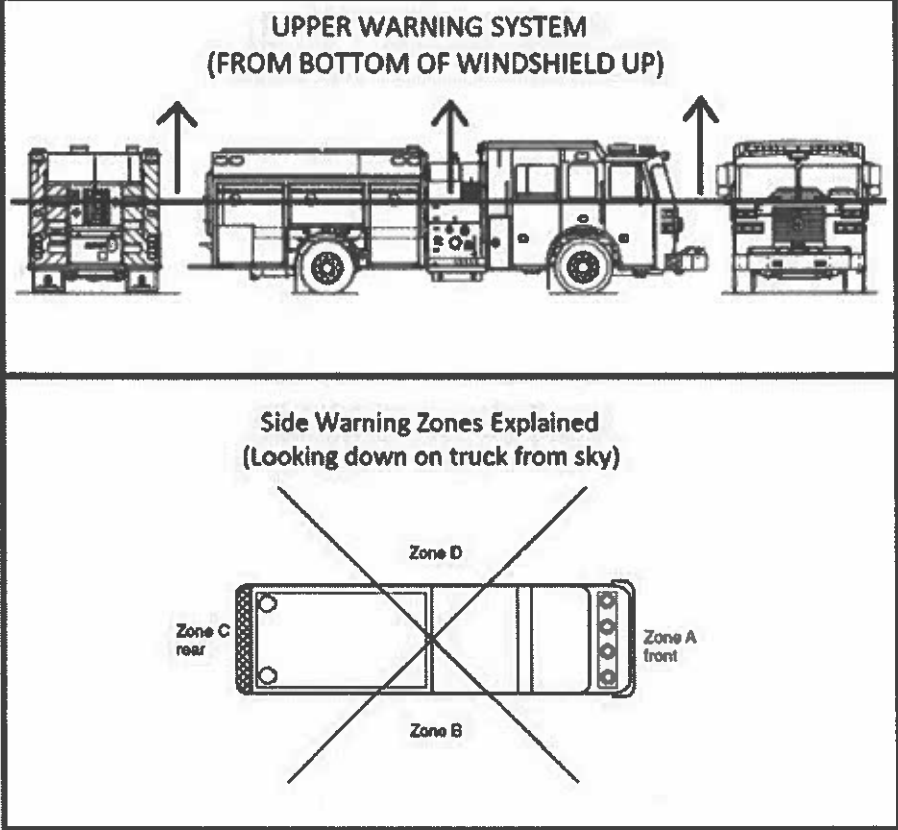
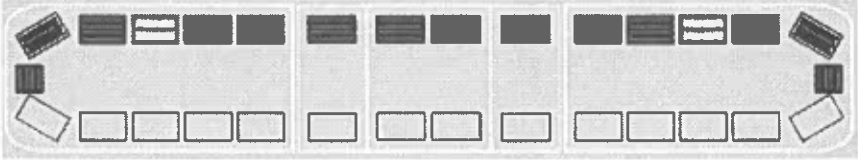
Line	Item #	Qty	Item Description/Comments
			<p style="text-align: center;">UPPER WARNING SYSTEM (FROM BOTTOM OF WINDSHIELD UP)</p>  <p style="text-align: center;">Side Warning Zones Explained (Looking down on truck from sky)</p>
440	86610140	1	UPPER WARNING LIGHTS, ZONE A (FRONT), WHELEN FREEDOM IV 72" LED LIGHT BAR, F4N7QLED, 16 MODULES
			
441	86920100	1	UPPER ZONE A LIGHTBAR, STANDARD CONFIGURATION
442		1	**ENG Zone A, Upper Lightbar Standard Configuration = Single light bar: (2) end red LED modules, (2) corner red LED modules, (10) forward-facing red LED modules and (2) forward-facing white LED modules. All clear outer lenses.
443	86699998	1	UPPER WARNING LIGHTS, ZONE B (OFFICER'S SIDE), COVERED BY ZONES A & C (Surface Mount)
444	86710310	1	UPPER WARNING LIGHTS, ZONE C (REAR), WHELEN LED, M9V2* SERIES SURFACE MOUNT, M9V2* (QTY 2)
445		1	**ENG Zone C, Upper Rear Beacon Color/Details = Red LED with Clear Lens. White lights shall be used as rear scene lights. Lights will have a switch labeled rear scene in both the driver and officers side. White lights shall also activate when vehicle is placed in reverse.
446	86899998	1	UPPER WARNING LIGHTS, ZONE D (DRIVER'S SIDE), COVERED BY ZONES A & C (Surface Mount)

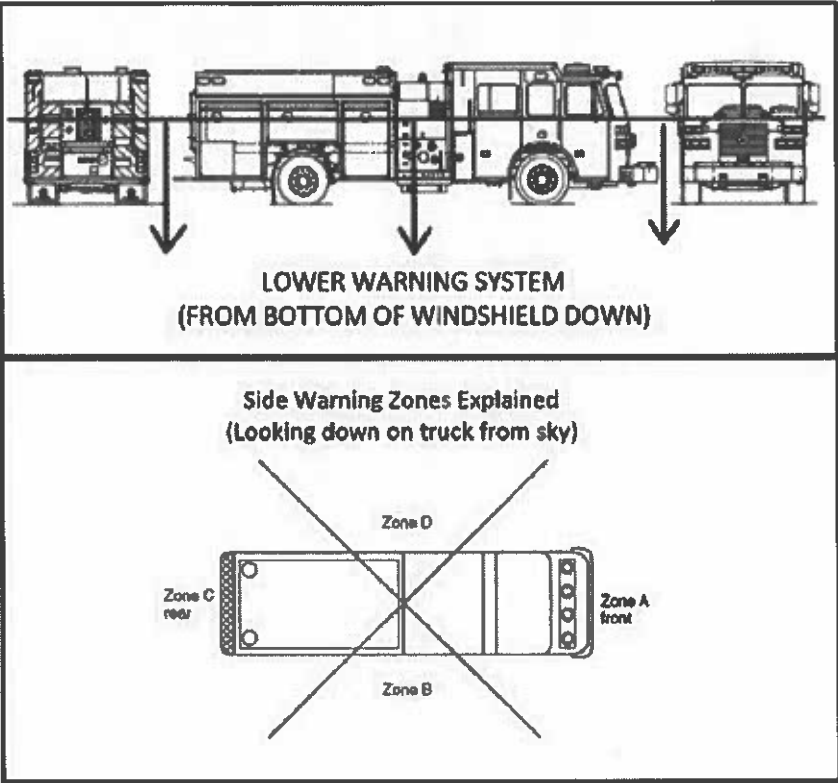
Line	Item #	Qty	Item Description/Comments
447	87100000	1	OPTICAL WARNING SYSTEM, LOWER (PUMPER)
			 <p style="text-align: center;">LOWER WARNING SYSTEM (FROM BOTTOM OF WINDSHIELD DOWN)</p> <p style="text-align: center;">Side Warning Zones Explained (Looking down on truck from sky)</p> <p style="text-align: center;">Zone D Zone C rear Zone A front Zone B</p>
448	87110210	1	LOWER WARNING LIGHTS, ZONE A (FRONT), WHELEN M6 LED, M6* (QTY 4)
449		1	**ENG Zone A, Lower Warning Light Color, Lens Color, Details = Red with clear lens
450	87811130	1	LOWER, ZONE A - MOUNTING LOCATION (DUAL HOUSINGS)
451		1	**ENG Zone A, Lower - Front, Mounting Location = (2) Warnings in top headlight housing, each side.
452	87530100	1	WARNING LIGHT FLANGES ON HEADLIGHT HOUSING FOR WHELEN M6 M6FC600 (6)
453	87210200	1	LOWER WARNING LIGHTS, ZONE B (OFFICER'S SIDE), WHELEN M6 LED, M6* (QTY 2), ION T-SERIES LED, TLI* (QTY 1)
454		1	**ENG Zone B, Lower Officer's Side Warning Light Color, Lens Color, Details = Red with clear lens
455	87812110	1	LOWER, ZONE B - MOUNTING LOCATION (PUMPERS, TANKERS, RESCUES)
456		1	**ENG Zone B, Lower - Officer's Side, Mounting Location = -(1) Warning Light near the front corner of the Apparatus. -(1) Warning Light near the rear Axle. -(1) Warning Light near the rear corner of the Apparatus. -Reference Shop Order Drawing for lights and placement.
457	87310100	1	LOWER WARNING LIGHTS, ZONE C (REAR), WHELEN 600 SUPER LED, 60*02F*R (QTY 2)

Line	Item #	Qty	Item Description/Comments
458		1	**ENG Zone C, Lower Rear Warning Light Color, Lens Color, Details = Red with clear lens
459	87410200	1	LOWER WARNING LIGHTS, ZONE D (DRIVER'S SIDE), WHELEN M6 LED, M6* (QTY 2), ION T-SERIES TLI* (QTY 1)
460		1	**ENG Zone D, Lower Driver's Side Warning Light Color, Lens Color, Details = Red with clear lens
461	87814110	1	LOWER, ZONE D - MOUNTING LOCATION (PUMPERS, TANKERS, RESCUES)
462		1	**ENG Zone D, Lower - Driver's Side, Mounting Location = -(1) Warning Light near the front corner of the Apparatus. -(1) Warning Light near the rear Axle. -(1) Warning Light near the rear corner of the Apparatus. -Reference Shop Order Drawing for lights and placement.
463	87590888	1	~UPGRADE WARNING LIGHTS
464	87537734	2	ADDITIONAL WARNING LIGHTS, WHELEN M6 LED, M6* (PAIR) (2)
465		1	**ENG Whelen M6 LED Warning Light Color = Red.
466		1	**ENG Whelen M6 LED Lens Color = Clear.
467		1	**ENG Whelen M6 LED Mounting Location = (1) Pair Mounted centered over front axle.(1) each side. (1) pair mounted on rear body (1) each side centered between tail light clusters and upper M9V2 warning lights.
468	87537738	1	ADDITIONAL WARNING LIGHTS, WHELEN ION T-SERIES LED, TLI*(PAIR) (1)
469		1	**ENG Whelen ION-T Warning Light Color = Red.
470		1	**ENG Whelen Ion-T Lens Color = Clear.
471		1	**ENG Whelen ION-T LED Mounting Location = Centered under the L1 and R1 compartment in the rub rail.
472	87537744	2	ADDITIONAL WARNING LIGHTS, WHELEN M9 SERIES LED, M9* (PAIR) (2)
473		1	**ENG Whelen M9 LED Warning Light Color = Red.
474		1	**ENG Whelen M9 LED Lens Color = Clear.
475		1	**ENG Whelen M9 LED Mounting Location = (1) each side of the body located in the upper most front and rear corners.
476	87537505	1	WARNING LIGHT, ROTO-RAY, LED
477		1	**ENG RotoRay Note: Chassis to provide/install RotoRay.
478	87040000	1	TRAFFIC ADVISOR, WHELEN LED, TAL65 36"
479	88391230	2	SCENE LIGHT, WHELEN PIONEER PFH2, 12V LED, TELESCOPIC W/SWITCH (2)

Line	Item #	Qty	Item Description/Comments
480		1	**ENG Scene Light Details = Mounted in the pump module driver and officer side facing outboard. -Switched in Overhead Console Position 1. "Left" and "Right Scene"
481		1	**ENG Scene Light Housings Color = White.
482	88393000	1	SCENE LIGHTS, FIRETECH 30K LUMENS, 12V LED, 72" 3-PIECE BROW, FT-B-72-ML-3PKIT-* (1)
483		1	**ENG ICC Cab Marker Lights Integrated in Brow Light = Yes
484	88393116	2	SCENE LIGHT, FIRETECH MB DOUBLE STACK 30.2", 12V LED, FIXED, 54 LED, FT-MB-2.27-FT-* (2)
485	88399940	3	ADDITIONAL SWITCH, 3-WAY FOR 12V LIGHTS (EA) (3)
486	86588888	1	SPECIAL ITEM, FIRETECH MB DOUBLE STACK FT-MB-2.18-REC, 12V LED, RECESSED, 36 LED (2)
487		1	**CLAR NOTES, Lights shall be recessed into the body (1) each side. Lights shall be centered over the L2 and R2 compartments.
488	10310410	1	PAINT & FINISH
PAINT & FINISH			
489	89910010	1	CORROSION REDUCTION PROGRAM (PROPOSALS)
490	90010020	1	PAINT SCHEME
491	90030010	1	TWO TONE CAB & BODY
492	90029910	1	PAINT BREAK #1 - BOTTOM OF WINDSHIELD
			
493		1	**ENG Upper Color for Two Tone Paint = PPG Black.
494		1	**ENG Lower Color for Two Tone Paint = PPG Burgundy.
495	90030155	1	PAINT FRAME RAILS & BODY REAR DROP - BODY COLOR

Line	Item #	Qty	Item Description/Comments
496	90030190	1	TEXTURED FRAME RAIL COATING
497	90680120	1	CHEVRON STRIPING, REAR BODY OUTBOARD, REFLEXITE
498		1	**ENG Chevron Striping, Rear Body Color = #030 Red Transparent & #L2 Fluorescent Lime.
499	10310420	1	EQUIPMENT
EQUIPMENT			
500	91010000	1	MISC EQUIP - (1) PINT TOUCH-UP PAINT, STAINLESS STEEL NUTS & BOLTS
501	91030700	1	ZIAMATIC SAC-44 FOLDING WHEEL CHOCKS (PAIR) MTD W/ SQCH-44H HOLDERS
502		1	**ENG Wheel Chock Mounting Locations = TBD@Precon
503	89030170	1	PIKE POLE, NUPLA 6' (1)
504	89030260	1	PIKE POLE, NUPLA 8' (1)
505	89040400	2	FIRE HOOKS UNLIMITED, 6' ALL PURPOSE HOOK (2)
506		1	**CLAR NOTES, Two 6ft "NY" style pike poles shall be provided.
507	92067705	6	STREAMLIGHT SURVIVOR 90509 LED W/12VDC FAST CHARGER (6)
508		1	**ENG Mounting Location = TBD@Precon
509	92067758	6	STREAMLIGHT SL-44451 FIRE VULCAN LED HANDLIGHT W/12 VOLT CHARGER (6)
510		1	**ENG Mounting Location = TBD@Precon
511	91531000	1	EXTINGUISHER 2 1/2 GALLON PRESSURIZED WATER W/MTG (1)
512	91532000	1	EXTINGUISHER 10 LB DRY CHEMICAL ABC W/MTG (1)
513	10310600	1	COMPLETION & WARRANTY
COMPLETION & WARRANTY			
514	99010100	1	MANUALS, ELECTRONIC VERSION (2-USB)
515	99031195	1	DEALER DELIVERY
516	99520110	1	WARRANTY, ONE YEAR

Line	Item #	Qty	Item Description/Comments
517	99521100	1	WARRANTY, FRAME, LIFETIME
518	99521200	1	WARRANTY, CAB STRUCTURAL, 10 YR.
519	99521300	1	WARRANTY, BODY STRUCTURAL, 10 YR.
520	99521400	1	WARRANTY, PAINT, 10 YR.
521	99521900	1	WARRANTIES, MAJOR VENDOR COMPONENTS
522	10310500	1	DEALER SUPPLIED
DEALER SUPPLIED			
523	Other	1	DEALER SUPPLIED - OTHER - Lazy Susan will pull out tray for Hydraulic tools.
524	Other	1	DEALER SUPPLIED - OTHER - (1) Mercury quick attack portable monitor model 3444 with fixed gallonage nozzle and following options (1) deluge tip part (1) Low expansion Master Stream Foam Tube
525	Other	1	DEALER SUPPLIED - OTHER - Purchase and programming of customer required radios that shall be shipped to Sutphen for installation. Customer radios are Harris model XL200 dual head and a Motorola Model 6500 VHF Dual Head. Programming will be completed by the radio shop for Sussex County Emergency Services. Any prices increase from time contract is signed until radios are purchased shall incur a change order and customer shall be responsible for payment prior to delivery of apparatus.
526	Other	1	DEALER SUPPLIED - OTHER - Graphics allowance
527		1	COOPERATIVE PURCHASING AGENCY FEES

BOARD ACTION FORM

Agenda Item: Action Item #6.03

Subject: Recommended Sussex County EMS Operations Plan – Thomas Hicks (Berkley Group)

Board Meeting Date: February 23 2023

=====

Summary: Thomas Hicks will be present at the meeting to discuss and provide recommendations

Recommendation: .

Attachment:

=====

ACTION: TBD

MOTION BY: _____ **SECONDED BY:** _____

<u>Member</u>	<u>Aye</u>	<u>Nay</u>	<u>Member</u>	<u>Aye</u>	<u>Nay</u>
Fly	___	___	W. Jones	___	___
Futrell	___	___	Seward	___	___
D. Jones	___	___	Tyler	___	___
			White (Tie Breaker)	___	___

BOARD ACTION FORM

Agenda Item: Action Item #6.04

Subject: Donation of Waverly Fire Department Engine 120 to Dickerson County

Board Meeting Date: February 23 2023

=====

Summary: Supervisor Fly has requested the donation of the Waverly Fire Department Engine 120 to Dickerson County.

Recommendation:

Attachments: N/A

=====

ACTION: That the Board approves the donation of the Waverly Fire Department Engine 120 to Dickerson County.

MOTION BY: _____ **SECONDED BY:** _____

<u>Member</u>	<u>Aye</u>	<u>Nay</u>	<u>Member</u>	<u>Aye</u>	<u>Nay</u>
Fly	___	___	W. Jones	___	___
Futrell	___	___	Seward	___	___
D. Jones	___	___	Tyler	___	___
			White (Tie Breaker)	___	___

BOARD ACTION FORM

Agenda Item: New Business #9.01

Subject: Presentation: New Solar Group

Board Meeting Date: February 23 2023

=====

Summary: Per the request of Supervisor Fly, the New Solar Group has been requested to be placed on the agenda to discuss concerns of the solar facility

Recommendation:

Attachments: Supervisor Fly's Email

=====

ACTION:

MOTION BY: _____ **SECONDED BY:** _____

<u>Member</u>	<u>Aye</u>	<u>Nay</u>	<u>Member</u>	<u>Aye</u>	<u>Nay</u>
Fly	___	___	W. Jones	___	___
Futrell	___	___	Seward	___	___
D. Jones	___	___	Tyler	___	___
			White (Tie Breaker)	___	___